

JUNIOR LYCEUM ANNUAL EXAMINATIONS 2008
DIRECTORATE FOR QUALITY AND STANDARDS IN EDUCATION
Educational Assessment Unit

FORM 3 (3rd year) GRAPHICAL COMMUNICATION (Tech. Des.) Time: 2 hours

NAME : _____

CLASS : _____

Instructions

- Write your name and class on all sheets.
- Attempt **ALL** questions.
- All answers are to be drawn accurately, with instruments, unless otherwise stated.
- All construction lines **MUST** be left on each solution to show the method used.
- Drawing aids may be used.

Information

- All dimensions are in millimetres.
- Estimate any dimension not given.
- Marks will be awarded for accuracy, clarity and appropriateness of construction.

Question	1	2	3	4	5
Max. mark	36	18	16	12	18
Mark					

1. The figure below shows a pictorial view of a **BRACKET**.
 Draw, in **third angle projection**, the following views:

- (a) a front elevation from arrow 'A'. **(including all hidden details)** 16 marks
 - (b) a complete plan. 15 marks
- Note: (i) Show the scale used. 2 marks
 (ii) Draw the symbol of projection used. 3 marks

Total 36 marks

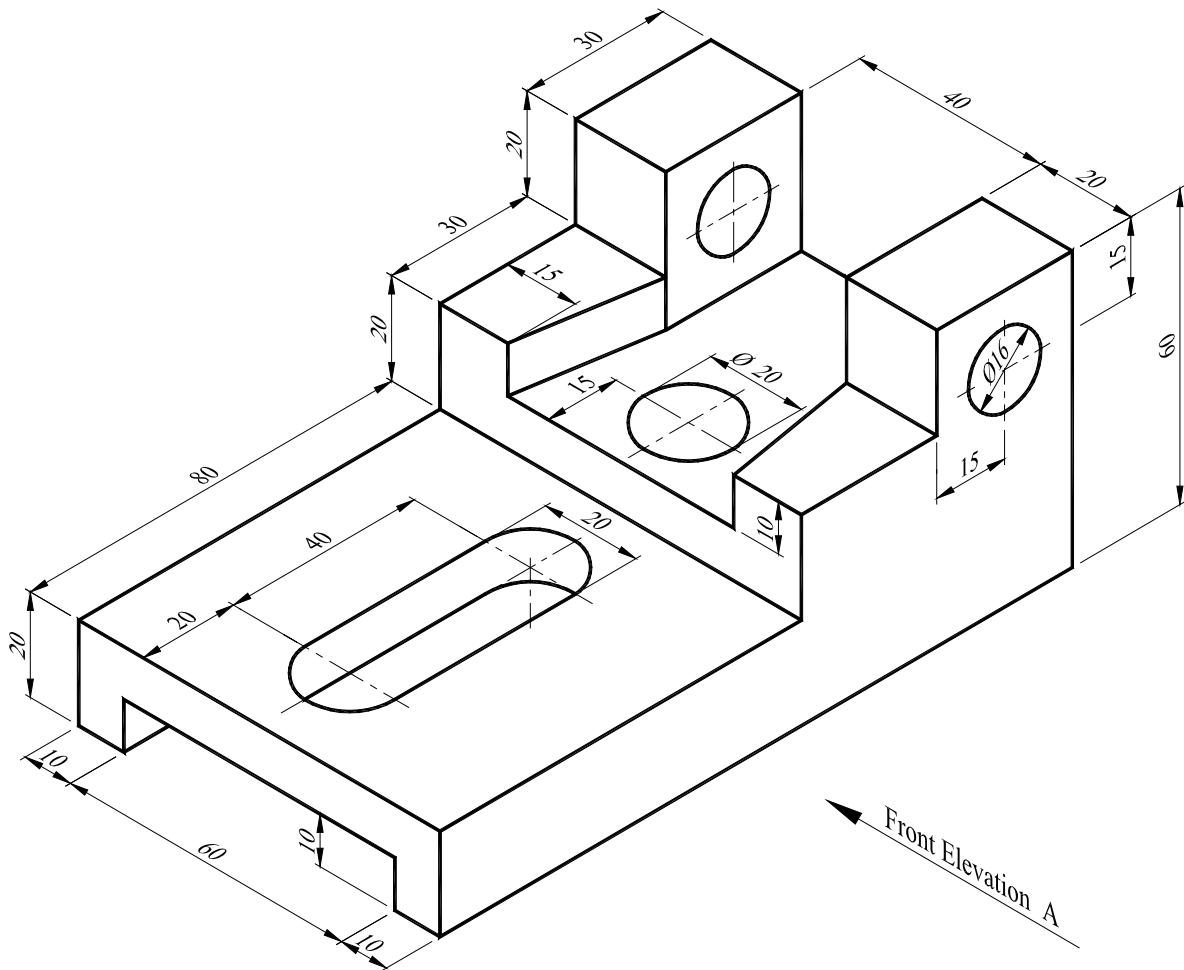

2. The drawing shows the outline of a small plastic toy. The arm is tangential to the ellipse at point 'P'. On the given centre lines, complete, full size, the outline of the toy. Clearly show your constructions for:
- the semi-ellipse (use any recognized method other than a trammel),
 - the line tangential to the ellipse.

18 marks

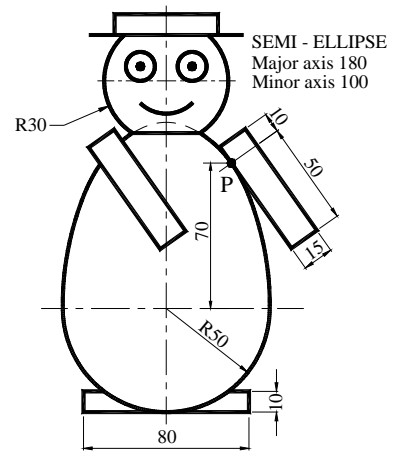

3. The figure below shows an orthographic projection in first angle of an 'Angle Vee Block'. Draw an isometric projection of the component, positioning face X in the foreground.

16 marks

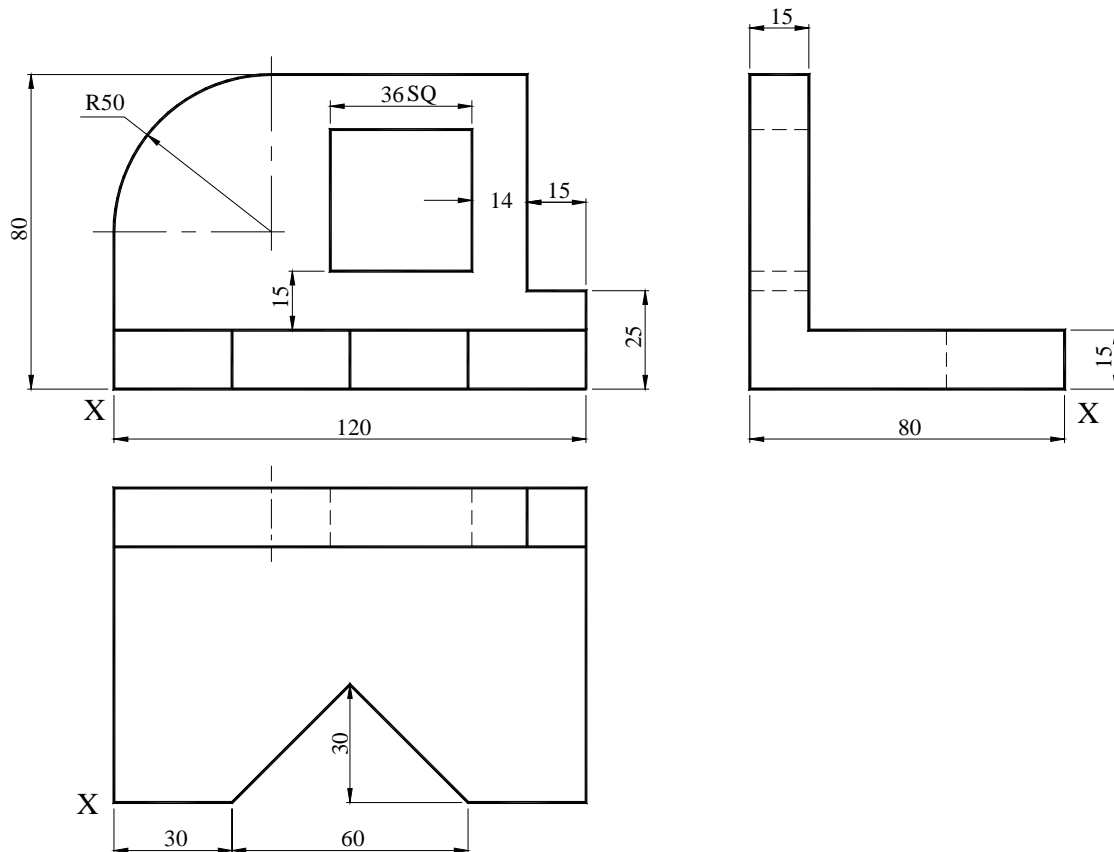

4. A template is shown in the figure below.
Using geometrical construction, enlarge the template proportionally if **AB** is extended to **C**.

12 marks

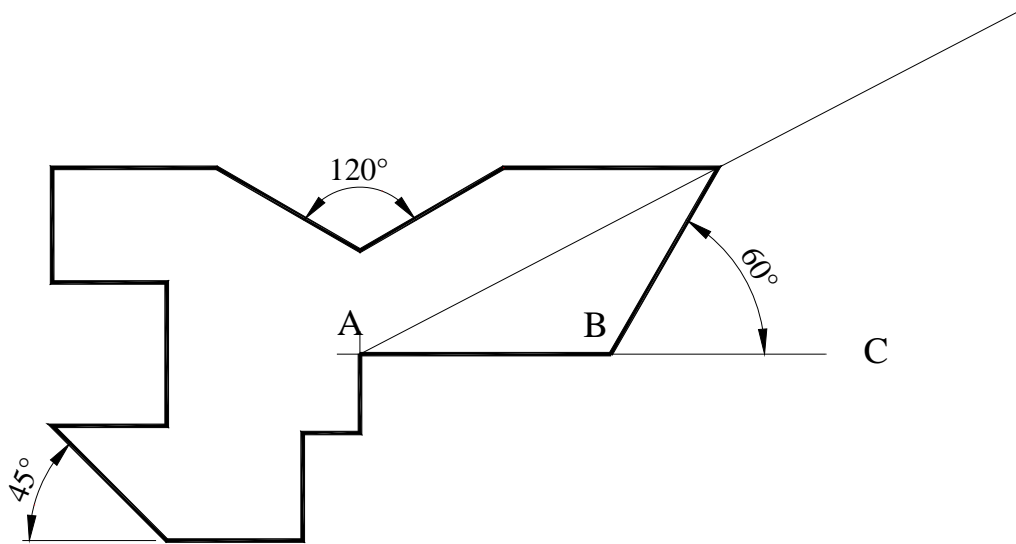

5. A view of a fan and a dimensioned detail drawing of one of the three blades are shown.
On the given centre lines draw **one** of the blades showing clearly the geometrical construction for finding the centres of the circular arcs.
All construction lines must be shown.
Note: The drawing of the blade given below is not to scale.

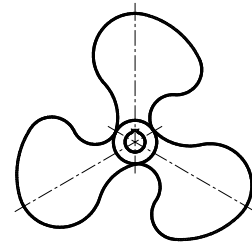

FAN

18 marks

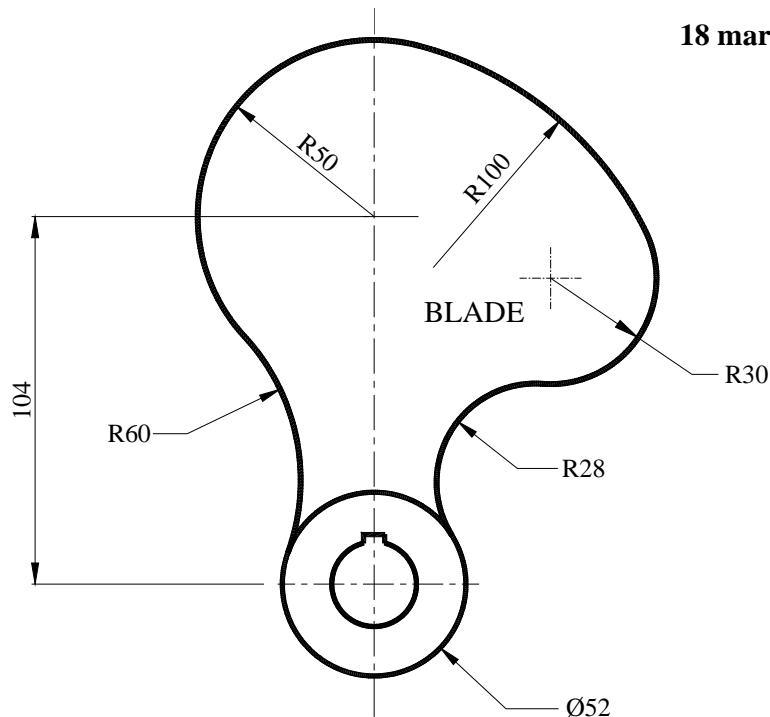

QUESTION No.1

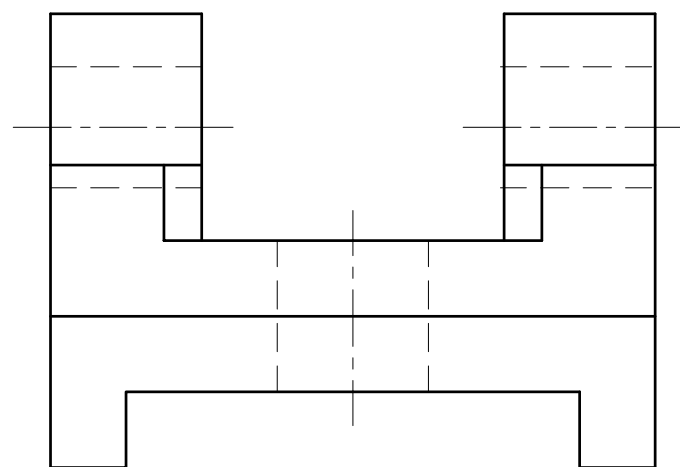

END ELEVATION

QUESTION No.2

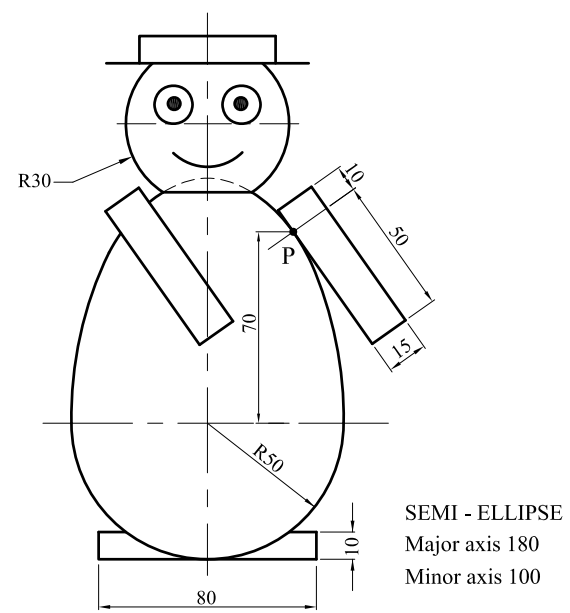
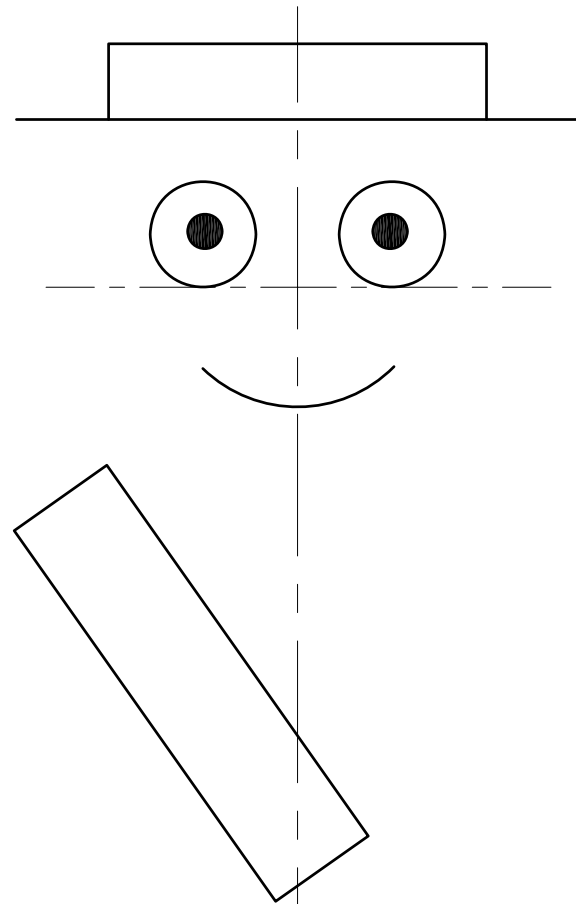

QUESTION No.3

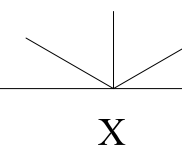

QUESTION No.4

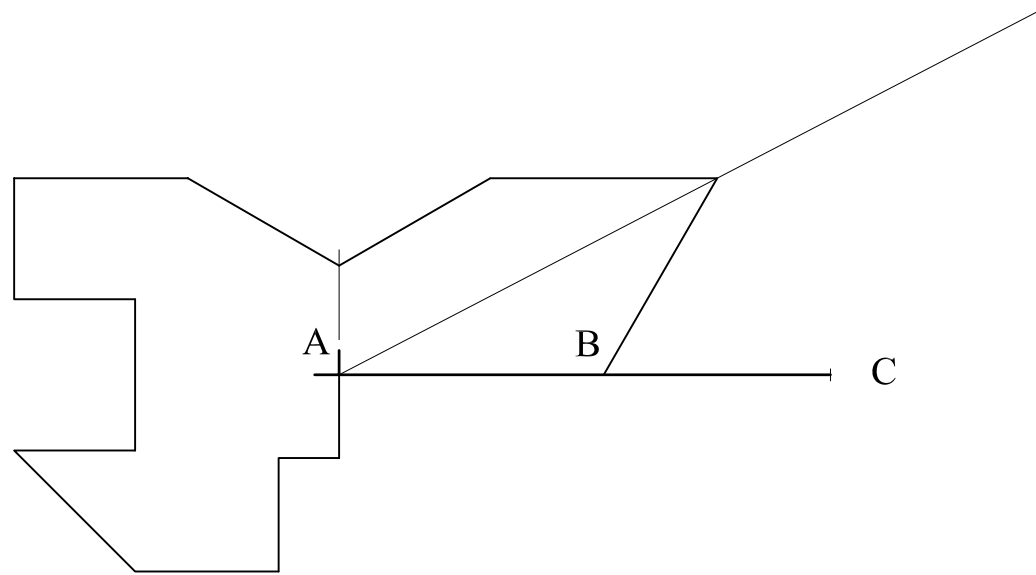

QUESTION No.5

