

SECONDARY SCHOOL ANNUAL EXAMINATIONS 2009

Directorate for Quality and Standards in Education
Educational Assessment Unit

FORM 2

GRAPHICAL COMMUNICATION

Time: 2 hours

NAME : _____

CLASS : _____

Instructions

- Write your name and class on all sheets.
- Attempt **ALL** questions.
- Answer all questions accurately, using instruments, unless otherwise stated.
- All construction lines **MUST** be left on each solution to show the method used.
- Drawing aids may be used.

Information

- All dimensions are in millimetres.
- Estimate any missing dimension.
- Marks will be awarded for accuracy, clarity and construction.

Question	1	2	3	4	5
Max. mark	36	14	16	16	18
Mark					

1. The figure below shows a pictorial view of a 'SHAPED BLOCK'.
 Draw full size, using first angle orthographic projection the following views:
- (a) a front elevation as seen from arrow 'A' 14 marks
 - (b) a plan. (Insert hidden details) 13 marks
- Include the following in your drawing:
- (i) the symbol of projection used 2 marks
 - (ii) in the Name Block provided, print in all the missing items, Name, Date, Title, etc. 7 marks

Total 36 marks

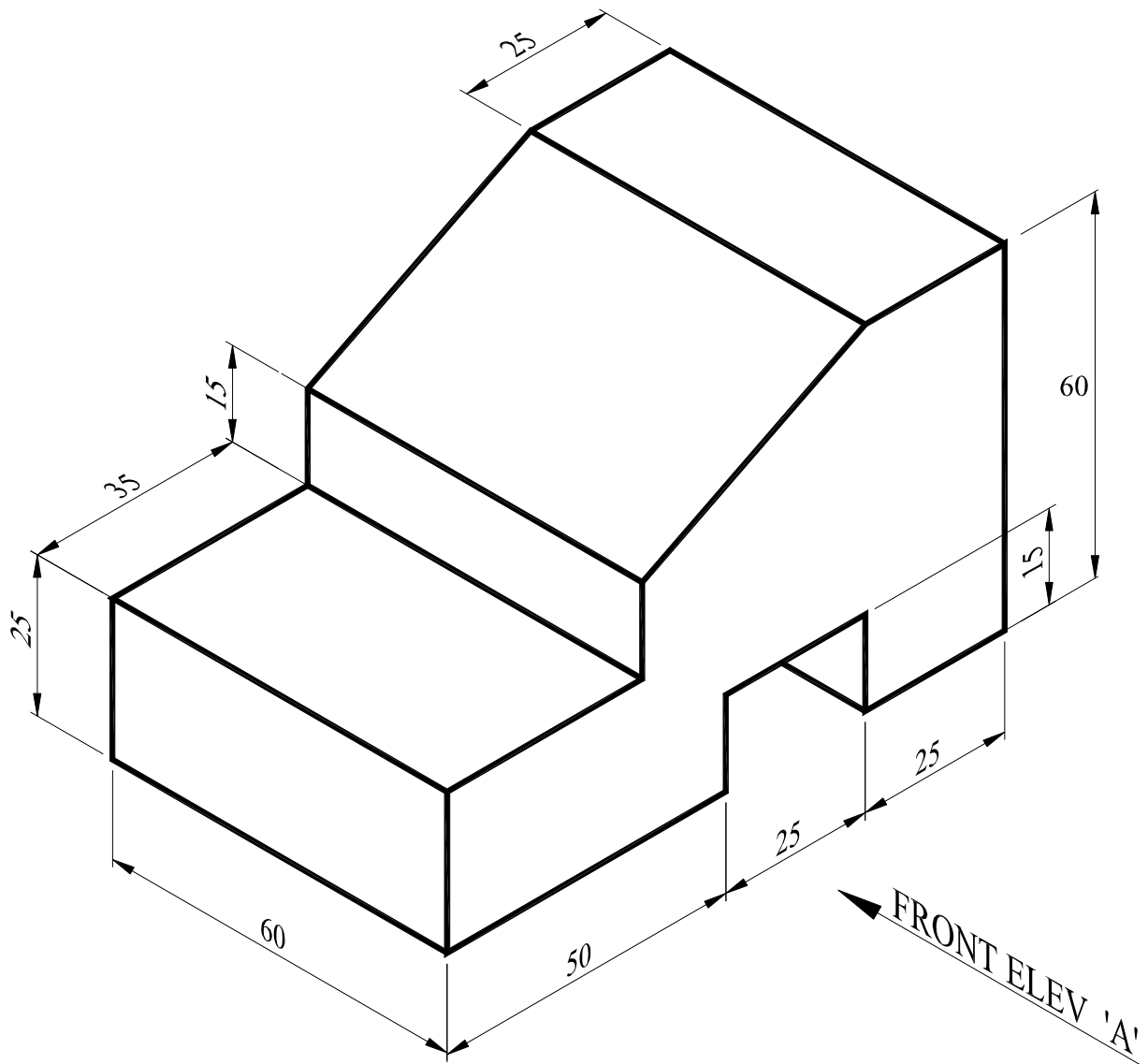

2. The figure below shows three views in first angle orthographic projection and an oblique view of a shaped block.
 Draw, to the dimensions given, an isometric view of the component, making 'X' the lowest corner in your drawing.

14 marks

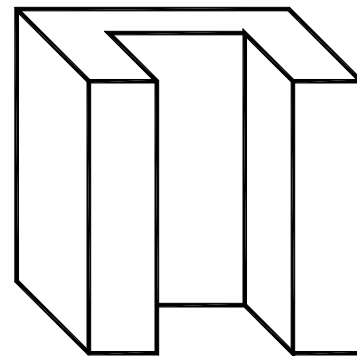
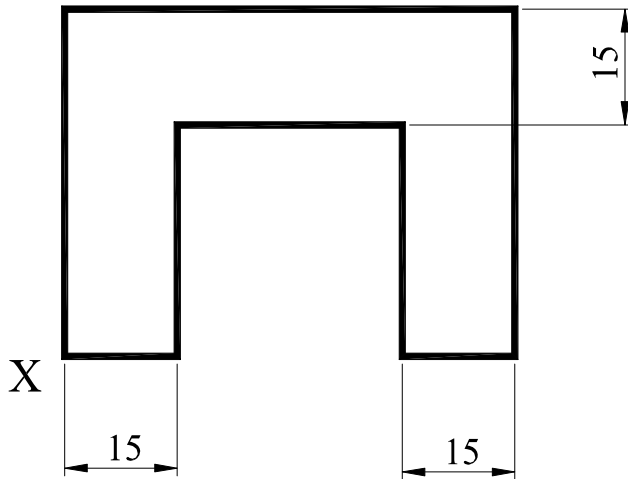
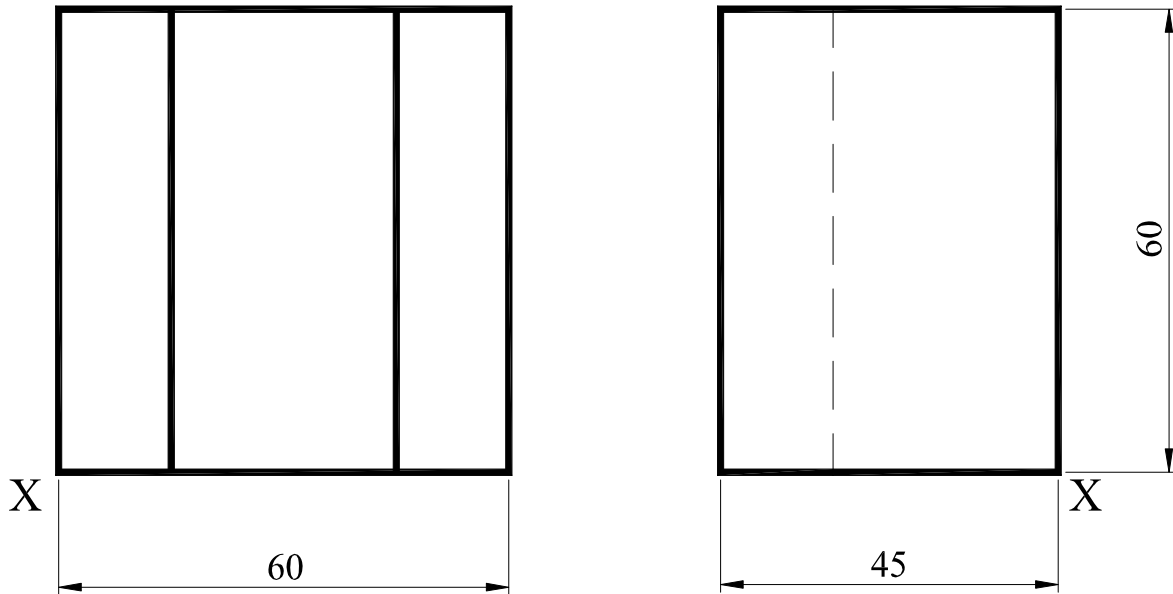

Oblique View

3. The figure below shows a roll kitchen paper holder.
 Within the given diagram on the starter sheet draw, using geometrical construction, the largest circle which can be placed in the holder and touching the given three sides.

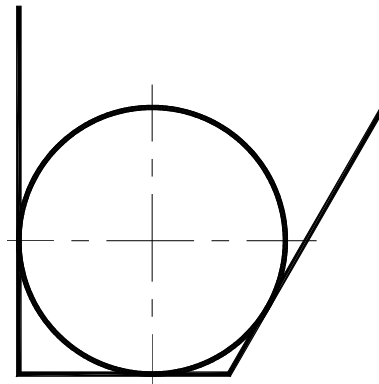

16 marks

4. Within the given circle shown on the starter sheet, construct geometrically a regular **pentagon**.
 Show all constructional details.

16 marks

5. The figure below shows, in first angle projection, an elevation and plan of a rectangular prism.
 Draw full size a one piece development of the prism including the top and base.



FRONT ELEV



PLAN

18 marks

QUESTION No.1

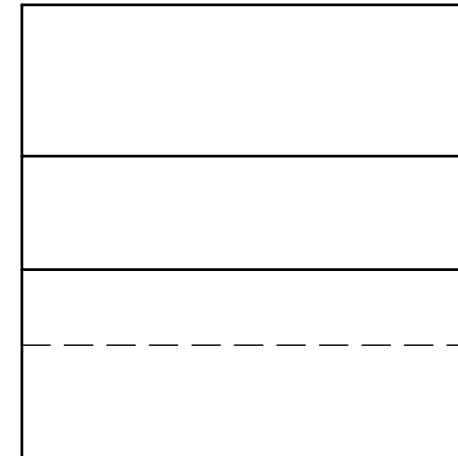
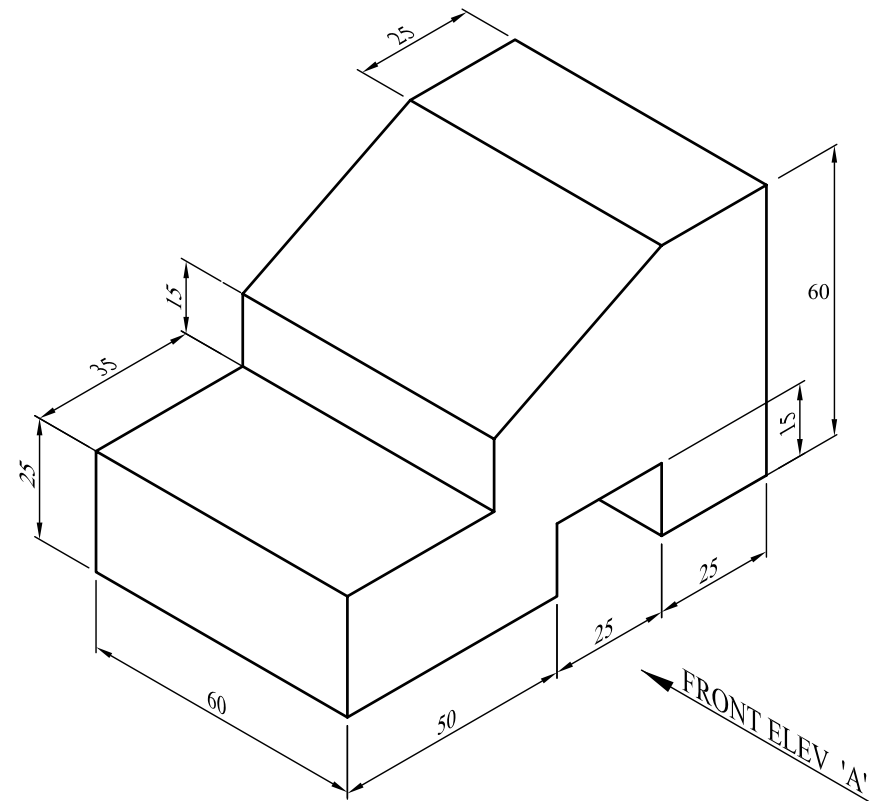

PROJECTION SYMBOL: -----

Scale 1 : 1

QUESTION No.2

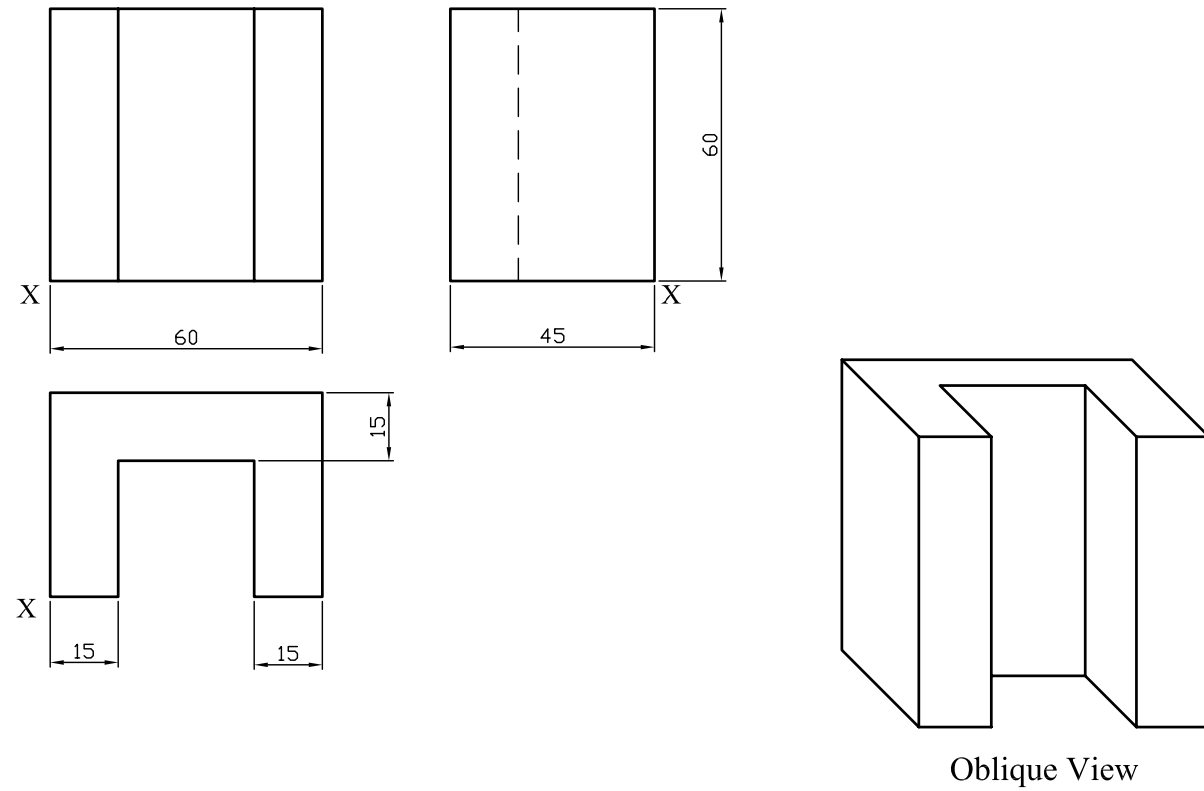

QUESTION No.3

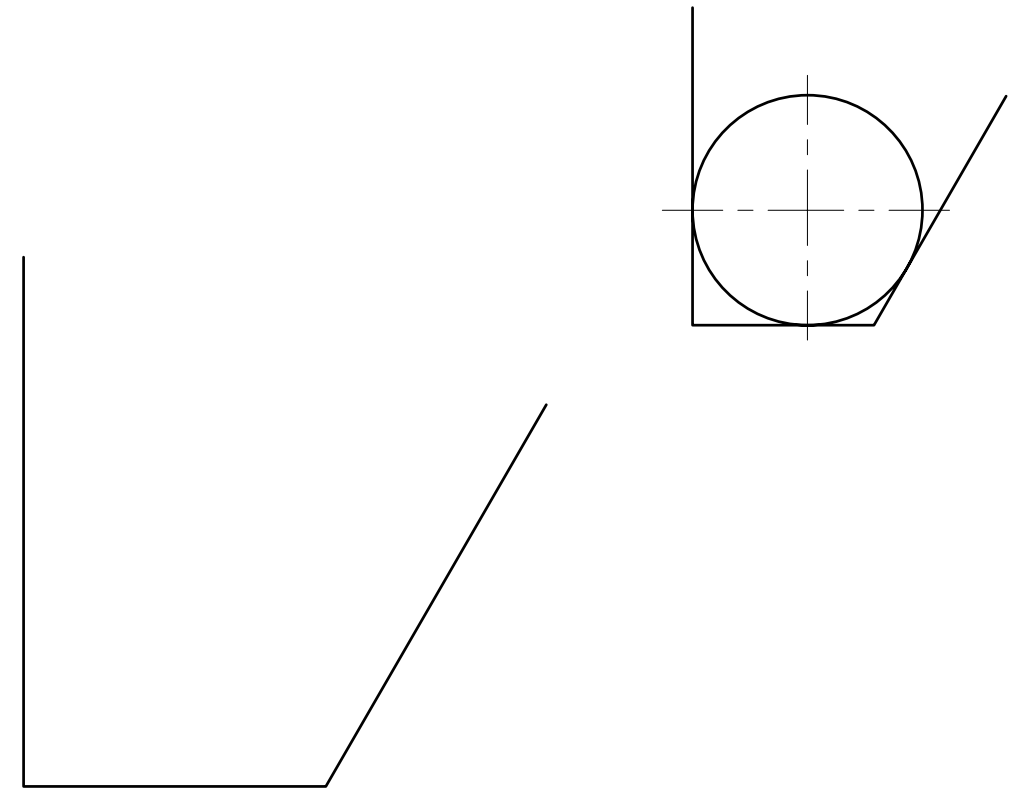

QUESTION No.4

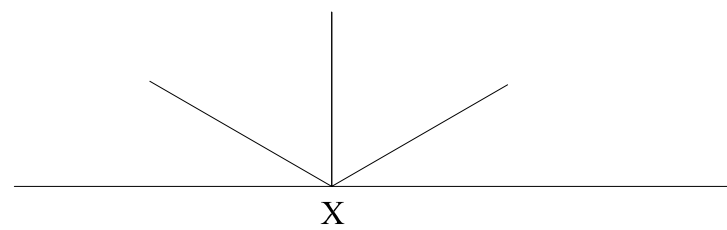
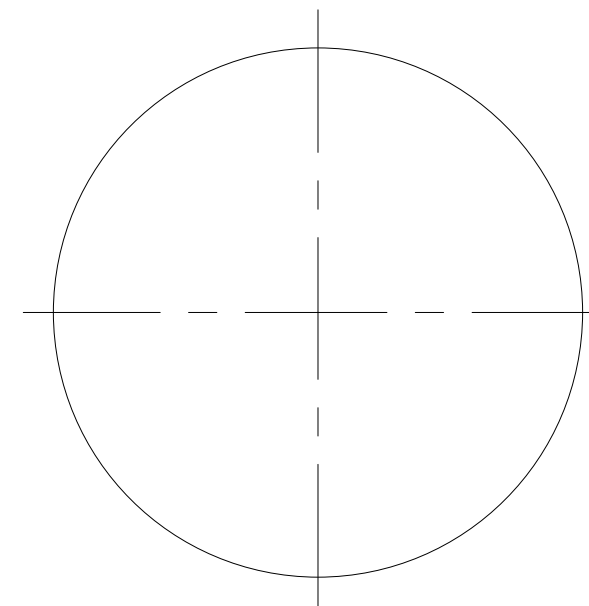

QUESTION No.5

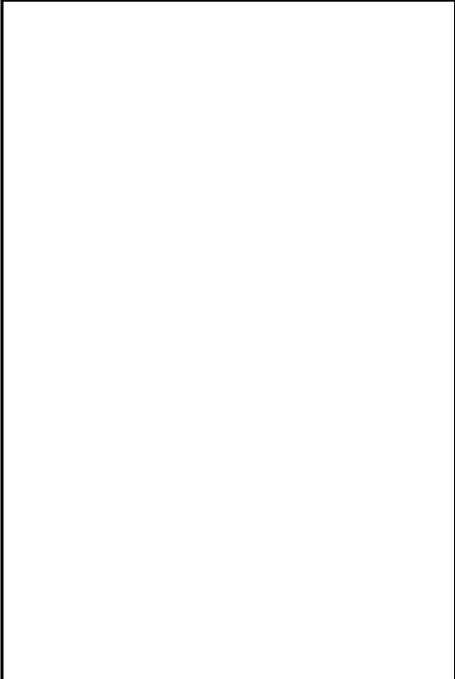

FRONT ELEV

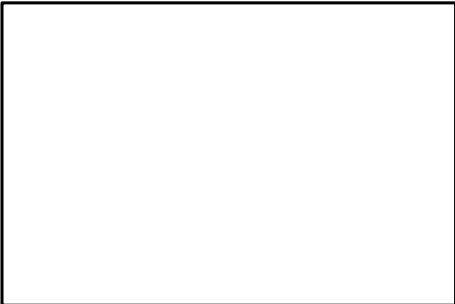

PLAN