

# JUNIOR LYCEUM ANNUAL EXAMINATIONS 2009

Directorate for Quality and Standards in Education  
Educational Assessment Unit

---

**FORM 4 (4<sup>th</sup> year)      GRAPHICAL COMMUNICATION      TIME: 2 hours**

---

**NAME** \_\_\_\_\_ **CLASS** \_\_\_\_\_

## Instructions

- Write your name and class on all sheets.
- Attempt ALL questions.
- All answers are to be drawn accurately, with instruments, unless otherwise stated.
- All construction lines **MUST** be left on each solution to show the method employed.
- Drawing aids may be used.

## Information

- All dimensions are in millimetres.
- Estimate any missing dimensions not given.
- Marks will be awarded for accuracy, clarity and appropriateness of construction.

Question	<b>1</b>	<b>2</b>	<b>3</b>	<b>4</b>	<b>5</b>
Max. mark	<b>36</b>	<b>14</b>	<b>14</b>	<b>18</b>	<b>18</b>
Mark					

1. The figure below shows an isometric view of a **SUPPORT BRACKET**.

- (a) Draw, full size, using third angle projection, the following views:
- (i) a complete front elevation looking in the direction of arrow 'A' including all hidden details in this view only. 12 marks
  - (ii) a sectional side / end elevation, the section being on X – X. 20 marks
- (b) Add the following to your drawing:
- (i) the appropriate symbol to indicate the projection angle. 4 marks
  - (ii) the scale.

**Total: 36 marks**

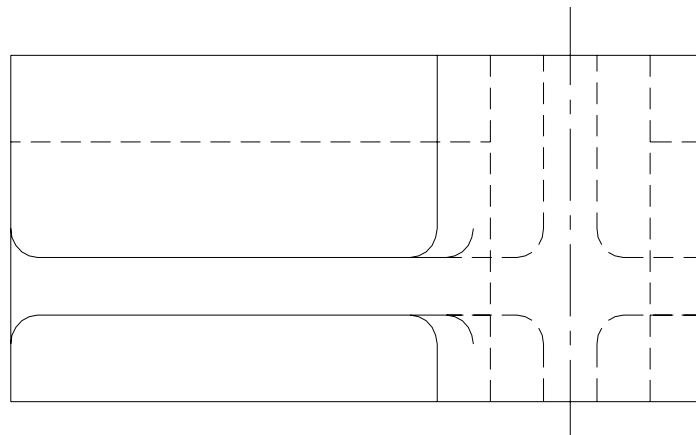
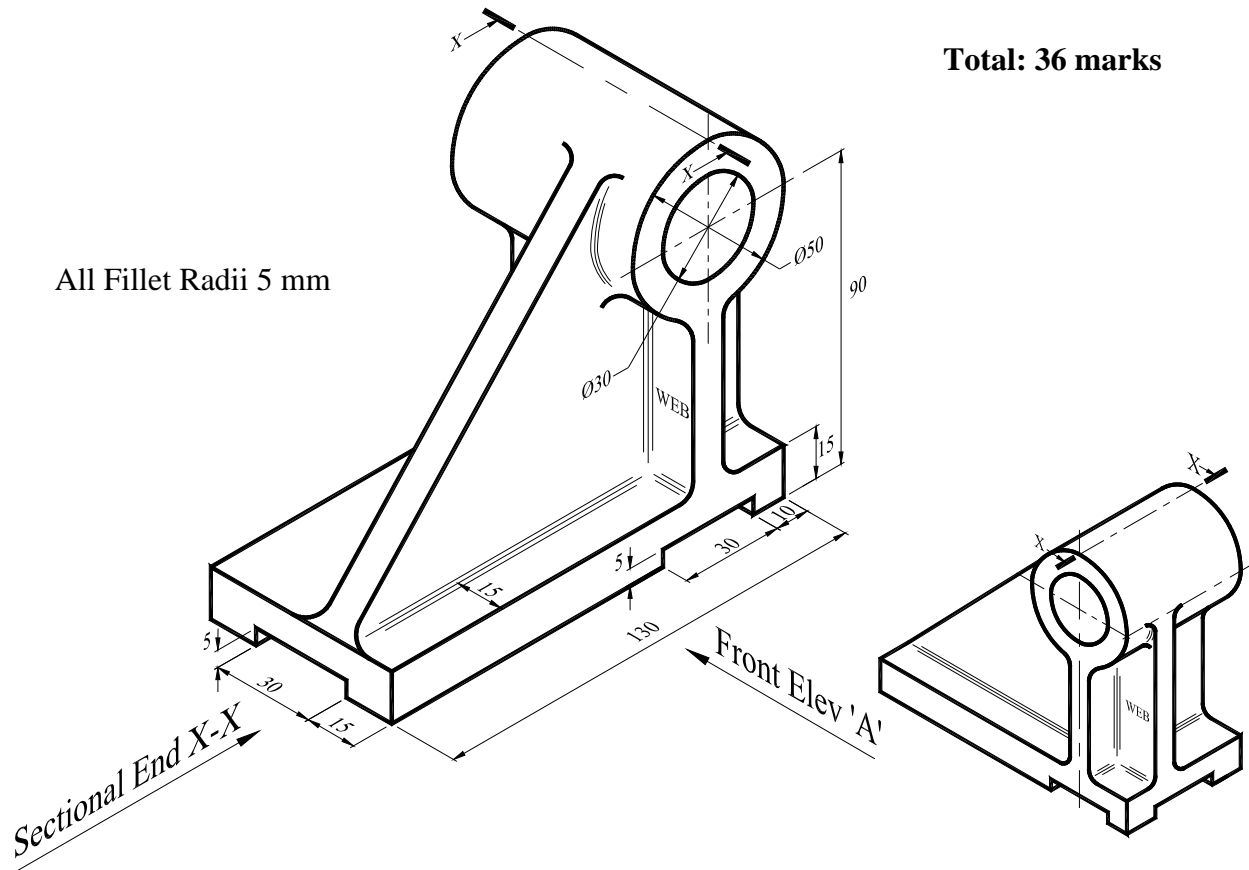

PLAN

2. A dimensioned profile and an incomplete version of a sea horse are given. Using the given centres on the starter sheet for the R12 and R23 circles, construct geometrically the remaining part of the sea horse.

All construction used to find the centres of all arcs is to be clearly shown.

Note: the drawing given is not drawn to scale.

14 marks

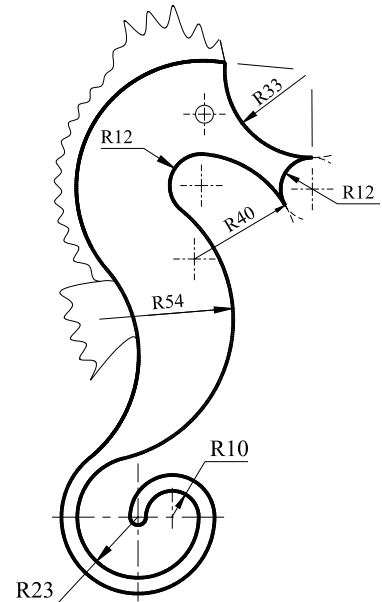

Not to scale

3. The figures below show a line diagram and a pictorial view of a simple mechanism. The disc rotates **clockwise** about centre C. Link PS is pin jointed to the disc at D, while end S is free to slide along the vertical centre line.

Using the line diagram given on the starter sheet, plot the locus of point P of link PS for one complete revolution of the disc (crank DC).

14 marks

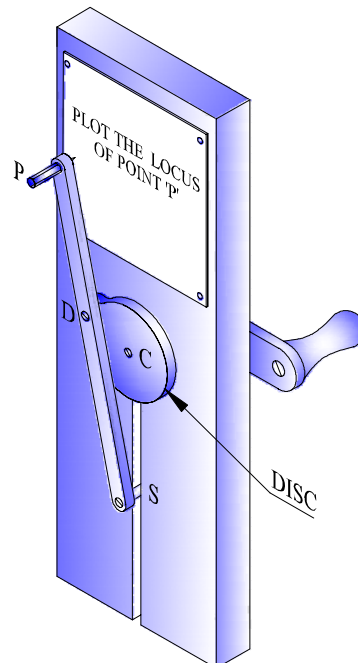
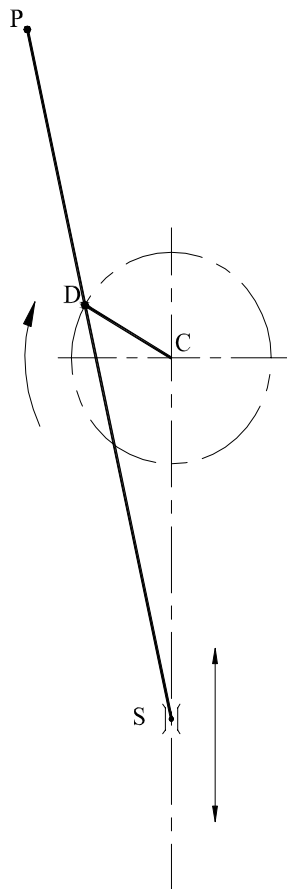

4. Three orthographic views and an isometric drawing of a Barbeque Area are shown below. Using the given start lines, draw a  $60^\circ / 30^\circ$  planometric view, positioning corner 'A' to appear in the foreground.  
**Note that the tiles measure 10mm x 10mm**

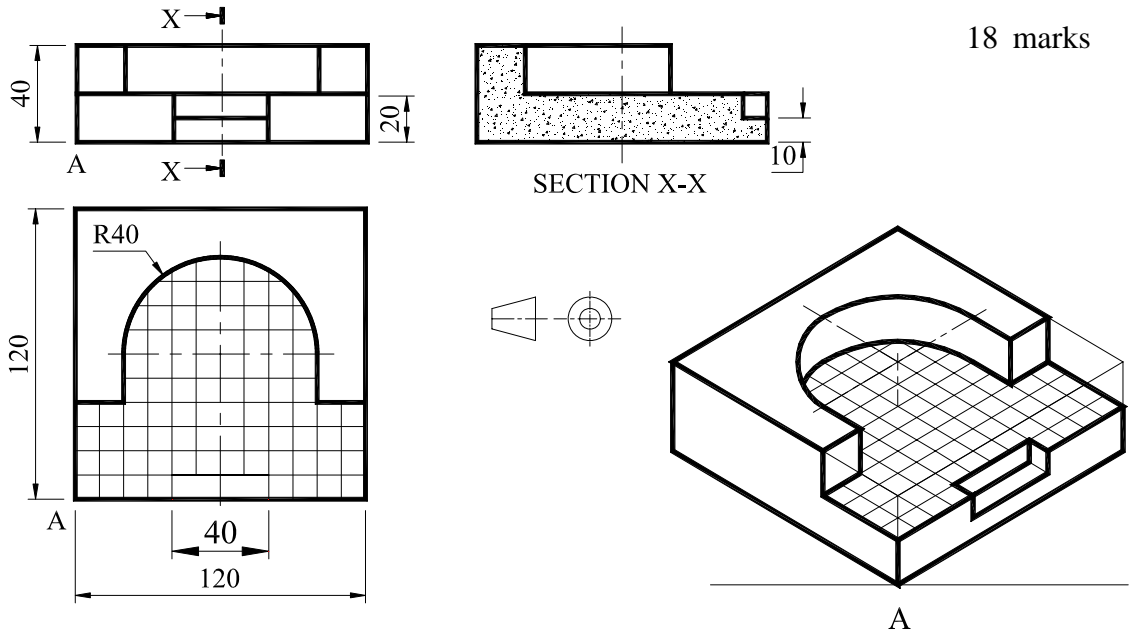

5. The figure shows an assembly of a key chain which consists mainly of an elliptical holder attached to a circular key ring.
- To a scale of  $2 : 1$ , construct the ellipse, using any recognized method other than a trammel, on the given start lines.
  - Draw the two blending (touching) arcs which are tangential to both the ellipse at point 'A' and the straight part of the key chain marked as 'B'.
- Note: that the centres of the radii, which are to be constructed geometrically, lie at the intersection of normals from A and B.

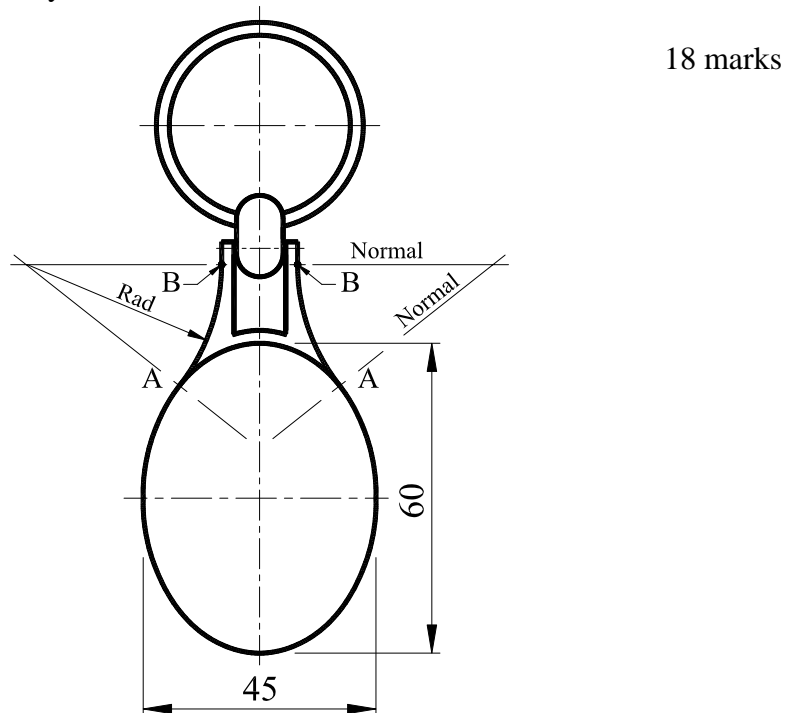

QUESTION No.1

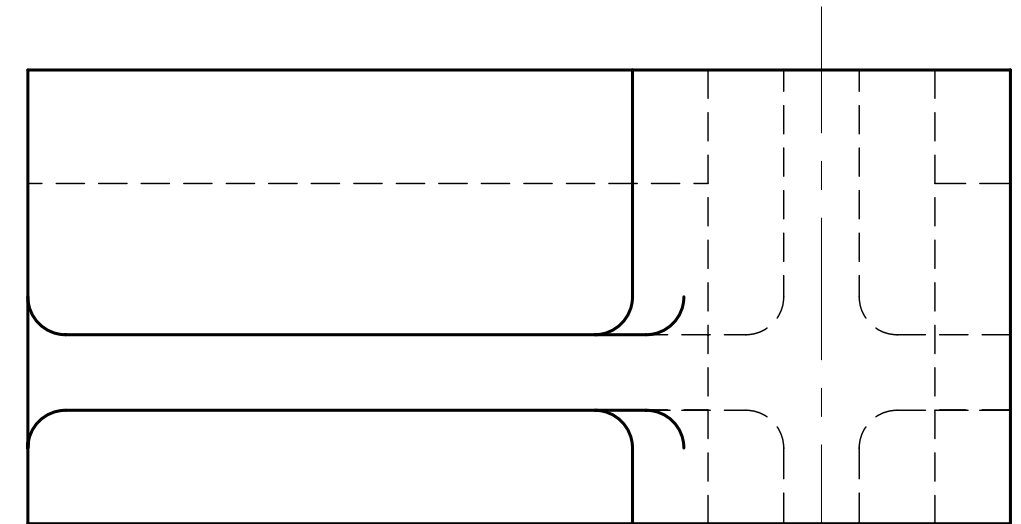
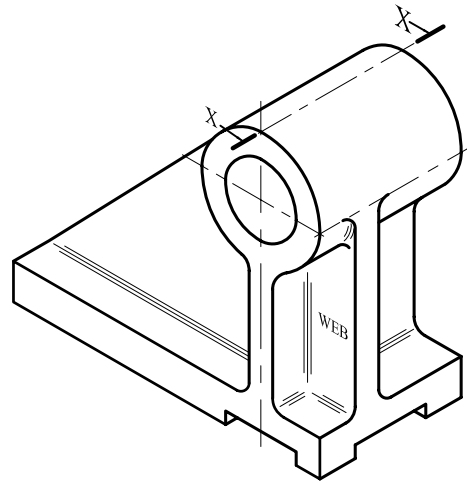

PLAN

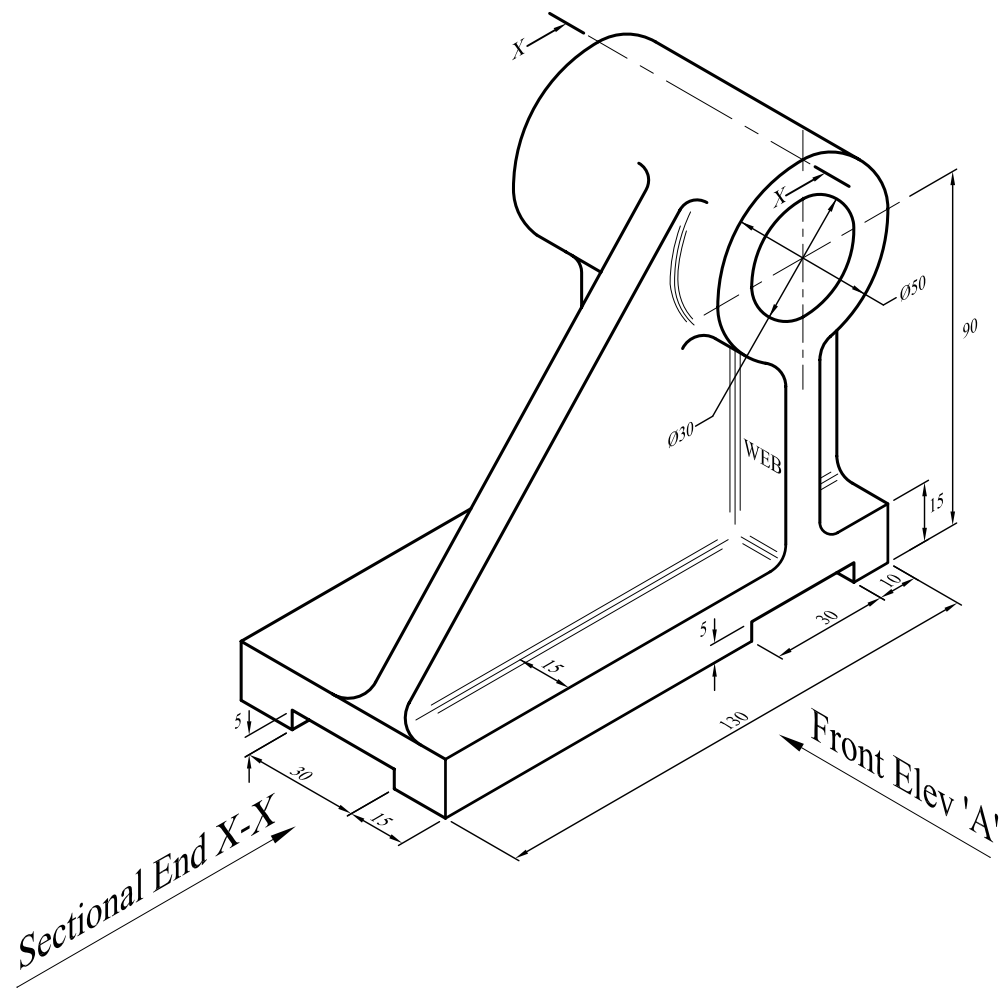
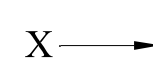

SECTION X - X

FRONT ELEVATION

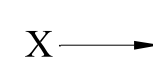

SCALE :

FILLET RADII 5mm

QUESTION No.2

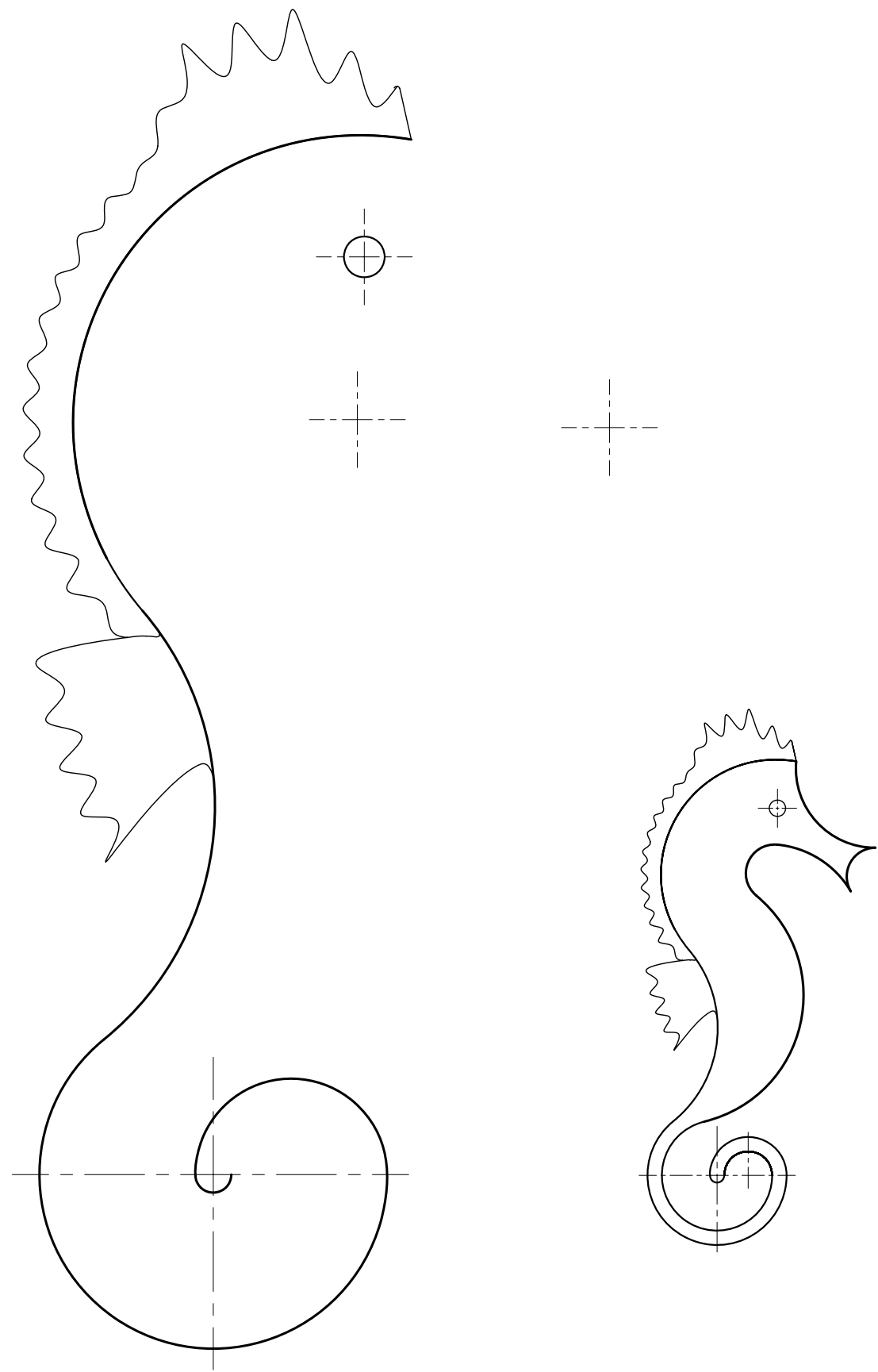

QUESTION No.3

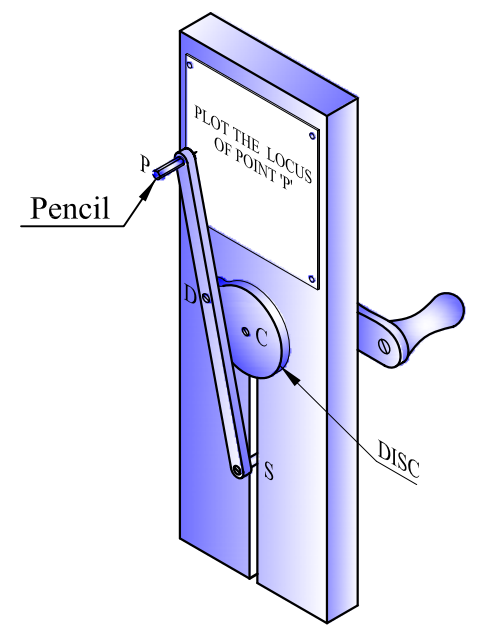
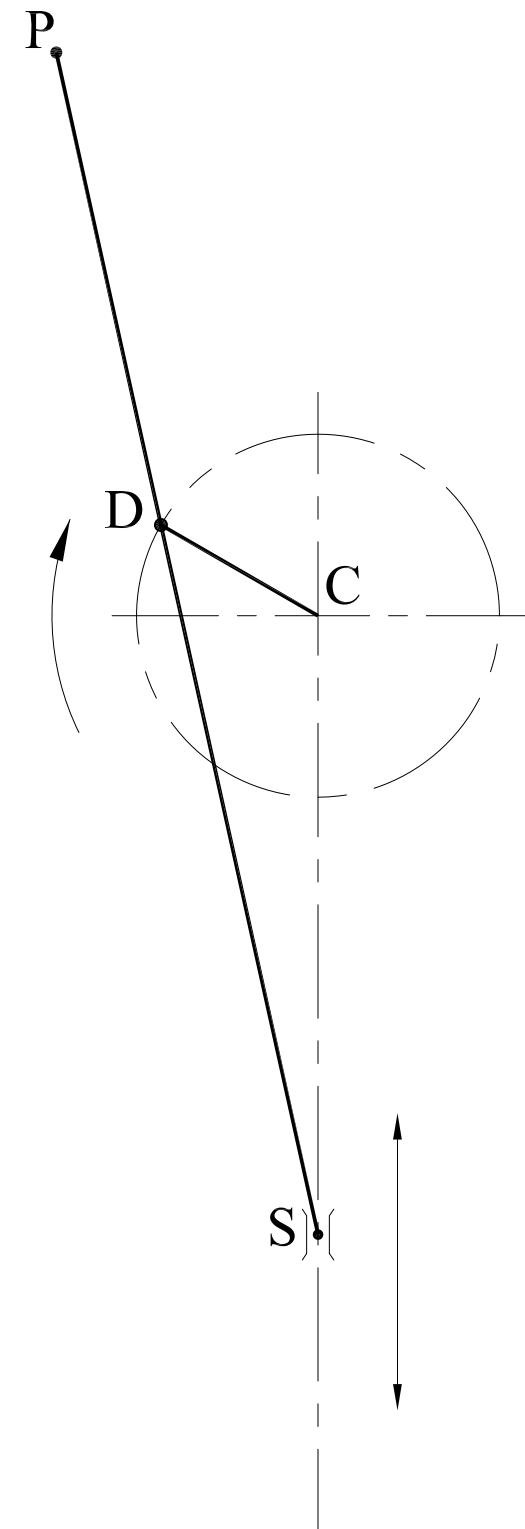

QUESTION No.4

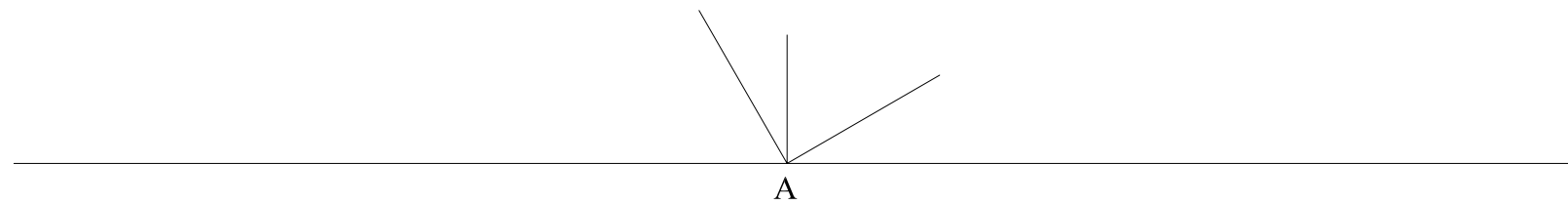
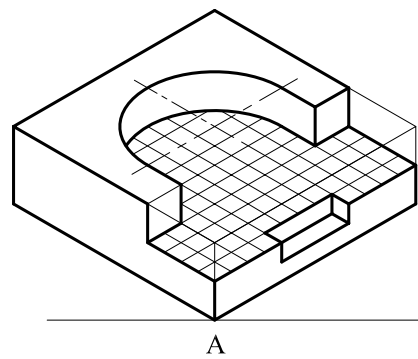
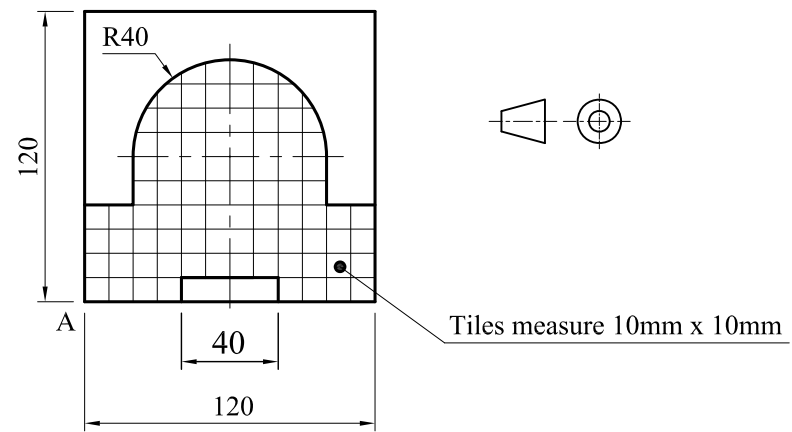
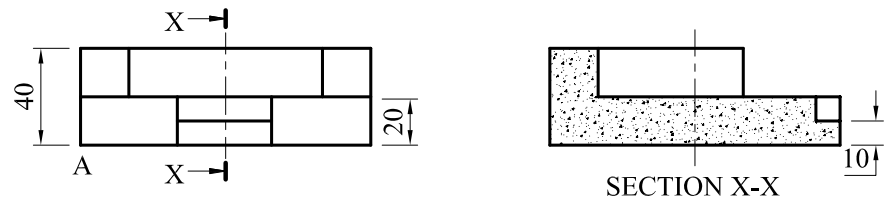

QUESTION No.5

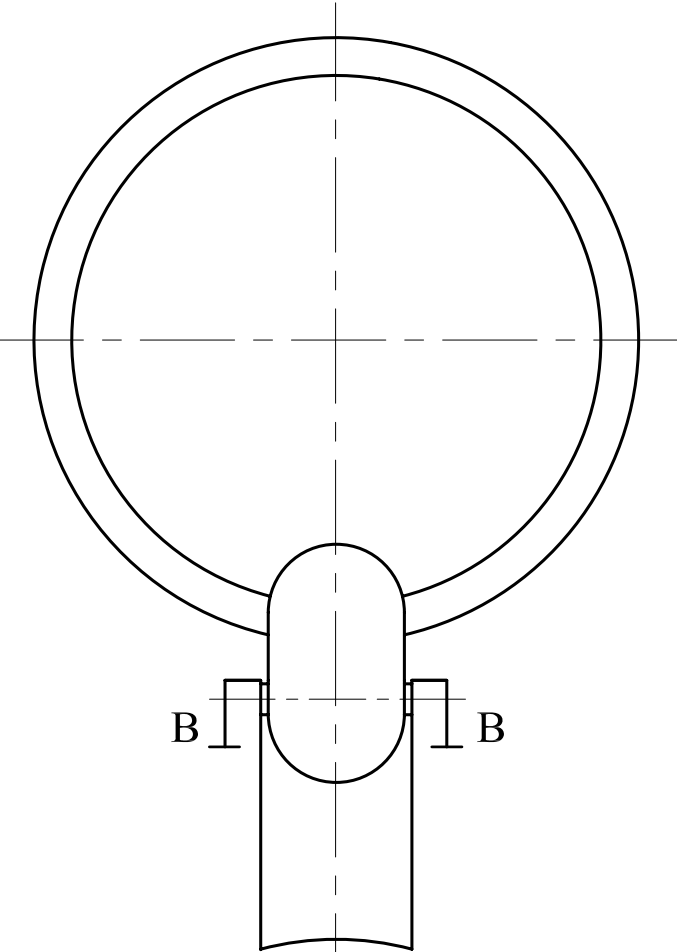
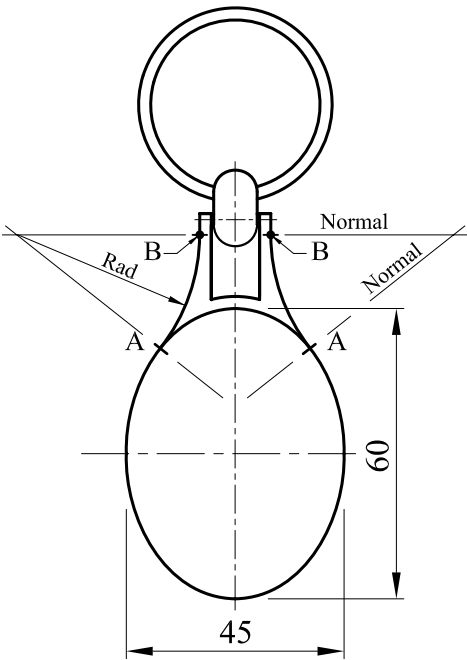

A \ / A

-----