

JUNIOR LYCEUM ANNUAL EXAMINATION 2004

Educational Assessment Unit – Education Division

---

**FORM 4 (4<sup>th</sup> year)                      TECHNICAL DESIGN                      Time 2 hours**

---

**Instructions**

- Write your name and class on all sheets.
- Attempt ALL questions.
- All answers are to be drawn accurately, with instruments, unless otherwise stated.
- All construction lines MUST be left on each solution to show the method employed.
- Drawing aids may be used.
- Colour / shading should be used where appropriate.

**Information**

- All dimensions are in millimetres.
- Estimate any missing dimensions not given.
- Marks will be awarded for accuracy, clarity and appropriateness of construction.

NAME \_\_\_\_\_

CLASS \_\_\_\_\_

Question	<b>1</b>	<b>2</b>	<b>3</b>	<b>4</b>	<b>5</b>
Max. mark	35	20	10	15	20
Mark					

1. The figure shows A MOUNTING BRACKET  
 From the plan which is drawn for you on the starter sheet project in third angle projection the following:

- (a) (i) a sectional front elevation on cutting plane A – A 20 marks  
 (ii) an end elevation looking in the direction of arrow X 10 marks
- (b) Add the following to your drawing  
 (i) the appropriate symbol to indicate the projection angle 5 marks  
 (ii) the scale 5 marks

Total: 35 marks

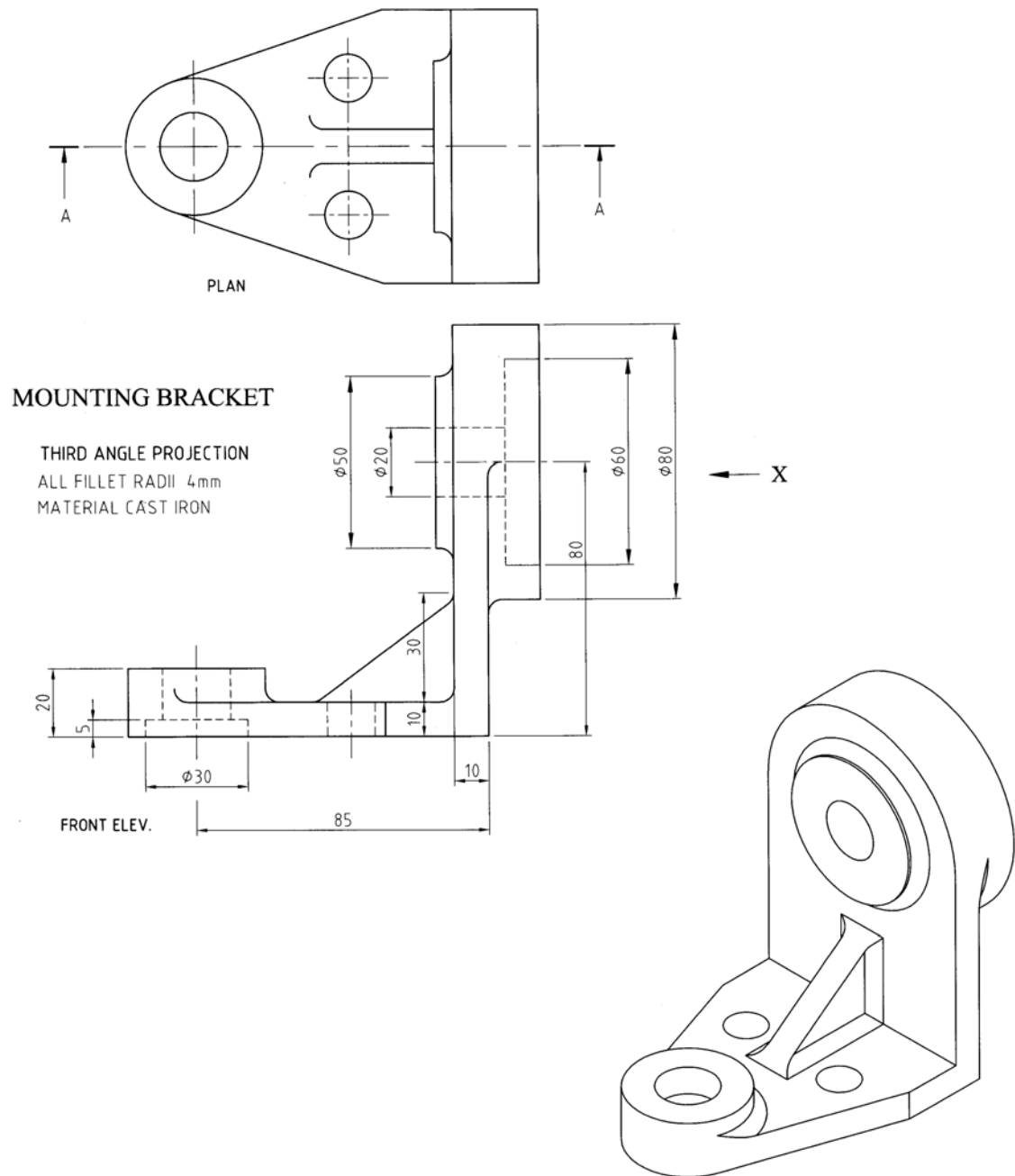

2. The table shows the results of a survey on the methods of travel to school by pupils in the different year groups.

METHODS OF TRAVEL	YEAR GROUPS				
	1	2	3	4	5
Walking	60	58	48	58	70
Bus	24	20	24	20	15
Bicycle	10	24	30	24	15
Motor Car	20	10	6	4	4
Absentees	6	8	12	14	16

- (a) Complete the Line Graph to show a comparison of the methods of travel to school by different year groups.
- (b) Complete the Pie Graph to show a comparison of the methods of travel to school by year group 3.
- (c) Add suitable colour and notation to your graphs.

Total: 20 marks

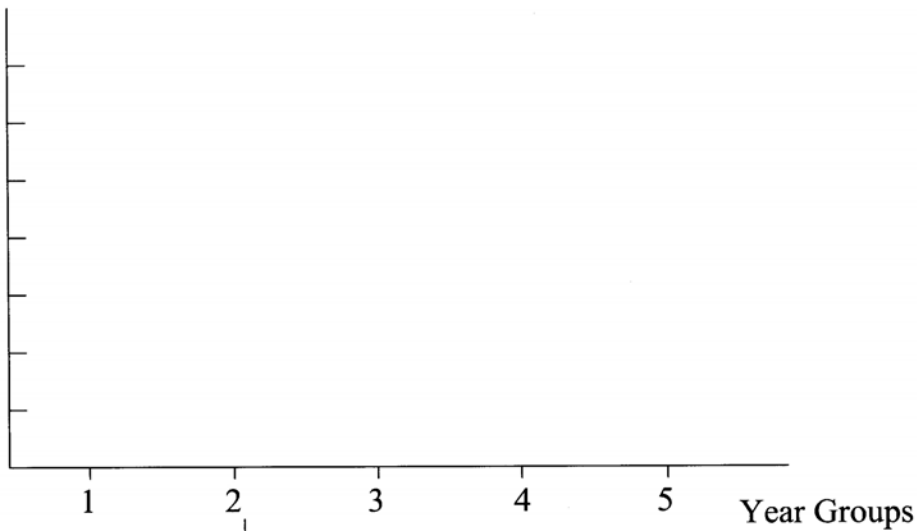

10 marks

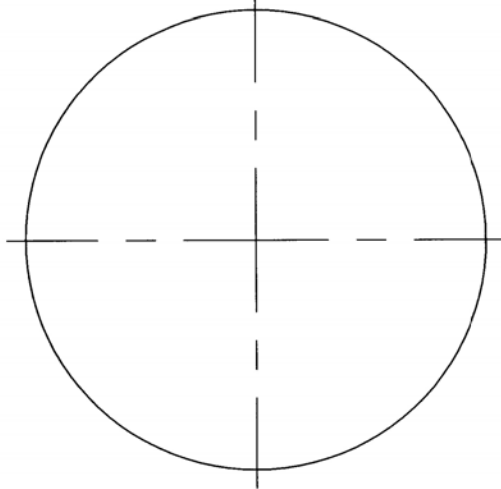

10 marks

3. The figure below shows an irregular pentagon 'ABCDE'. By means of geometrical construction draw a square having the same area as the given pentagon. Measure and state the length of the side of the square to the nearest millimeter.

10 marks

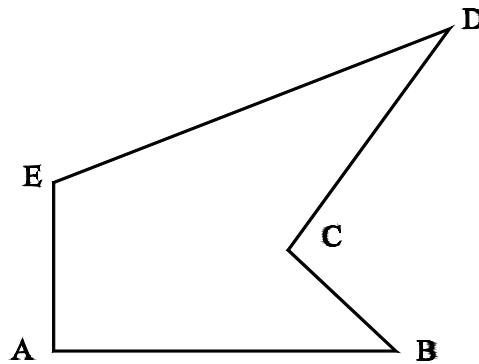

4. In the off-set crank mechanism shown, the slider – end B moves in guides along the line CD, below the axis O of the crank. Plot the locus of point P on rod AB for one complete revolution of crank OA

15 marks

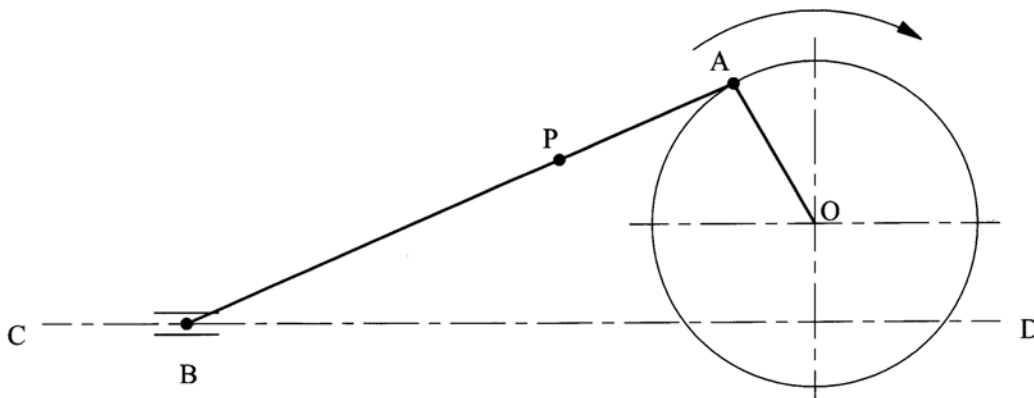

5. The figure below shows a complete surface development, a plan view and an incomplete front elevation of a sheet metal component.

Draw full size, the wrapped component when viewed in the direction of arrow 'X'

Note: That the joint line 'A A' of the wrapped development is to be placed in front as indicated in the incomplete front elevation and plan views.

20 marks

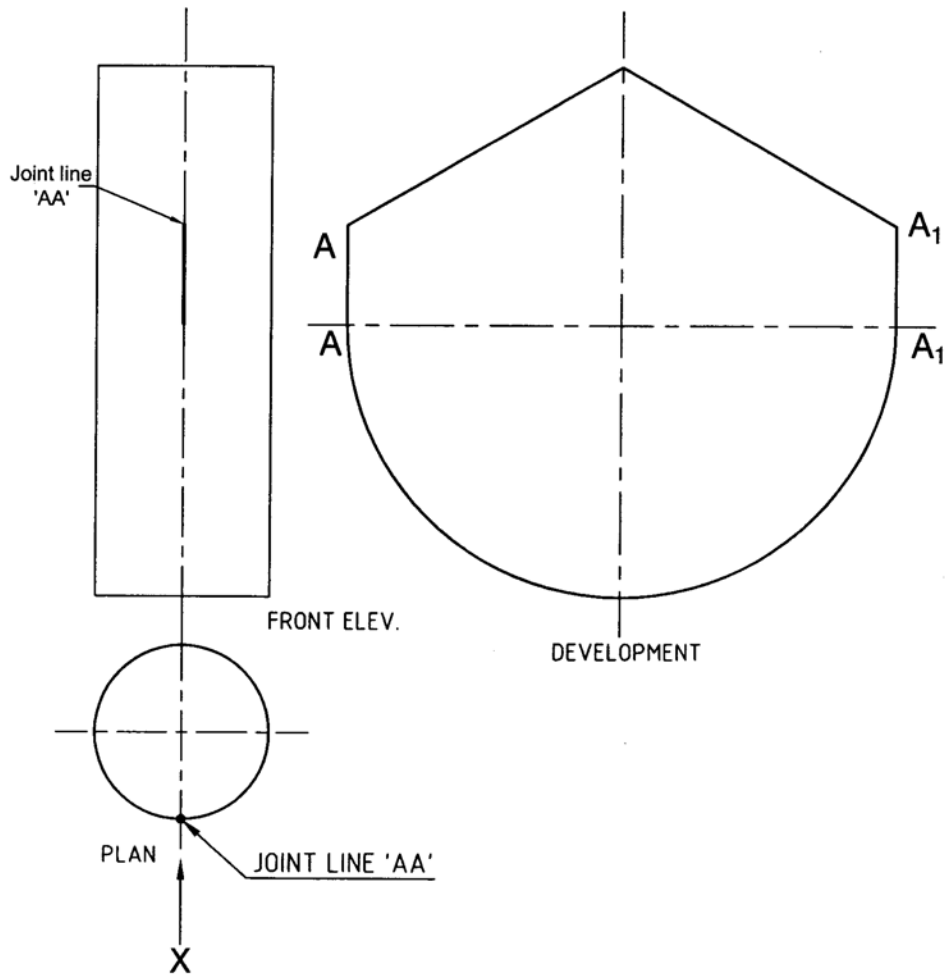

1. The figure shows A MOUNTING BRACKET  
From the given plan which is has been drawn for you project in third angle projection  
the following:

- (a) (i) a sectional front elevation on cutting plane A - A  
(ii) an end elevation looking in the direction of arrow X

- (b) Add the following to your drawing  
(i) the appropriate symbol to indicate the projection angle  
(ii) the scale

35 marks total

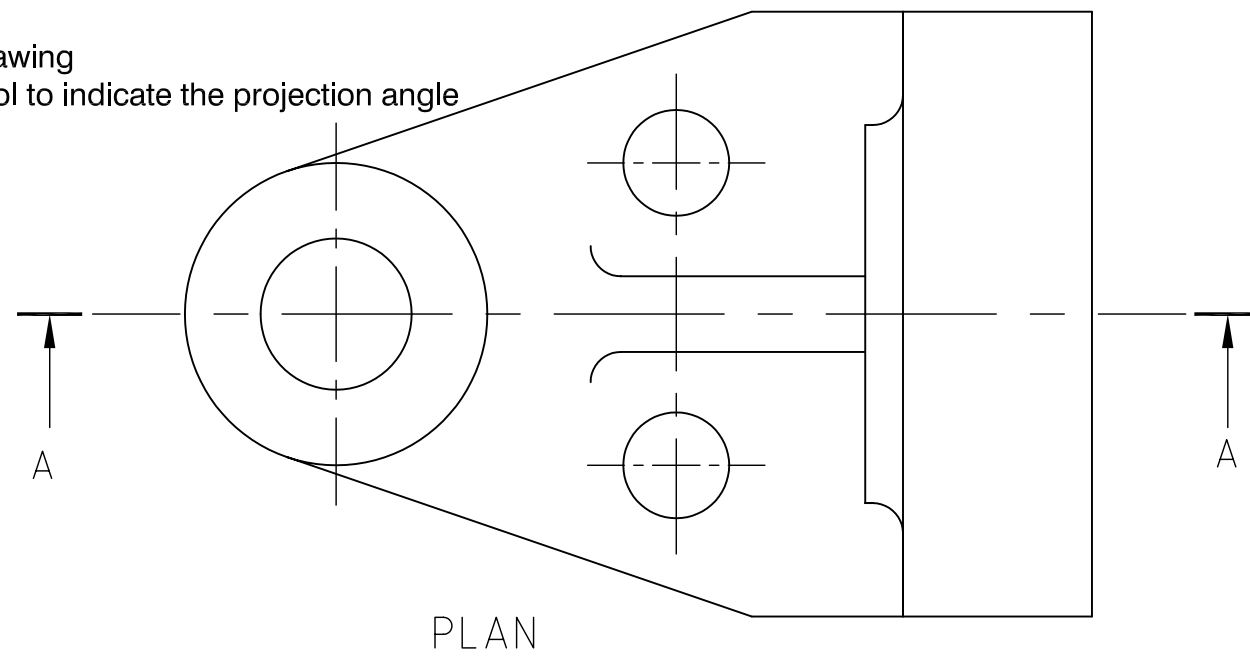

2. The table on the attached answer sheet, shows the results of a survey on the methods of travel to school by pupils in the different year groups.

- (a) Complete the Line Graph to show a comparison of the methods of travel to school by different year groups.
- (b) Complete the Pie Graph to show a comparison of the methods of travel to school by year group 3.
- (c) Add suitable colour and notation to your graphs.

Total: 20 marks

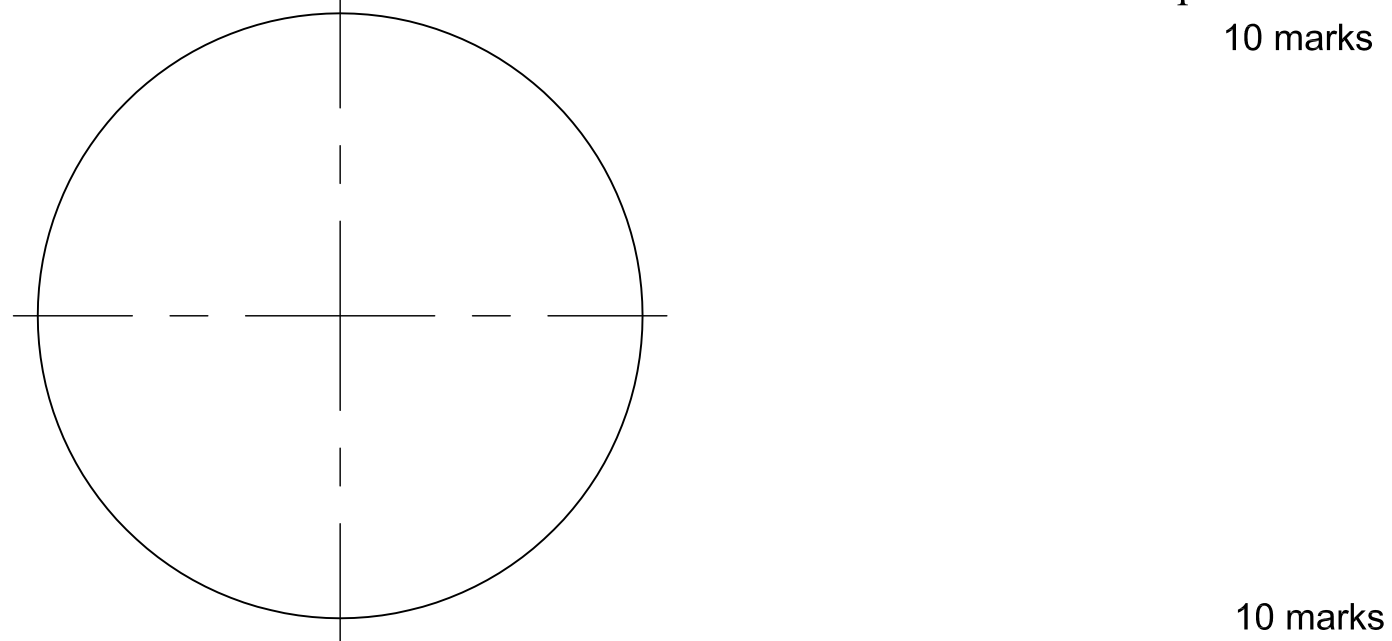
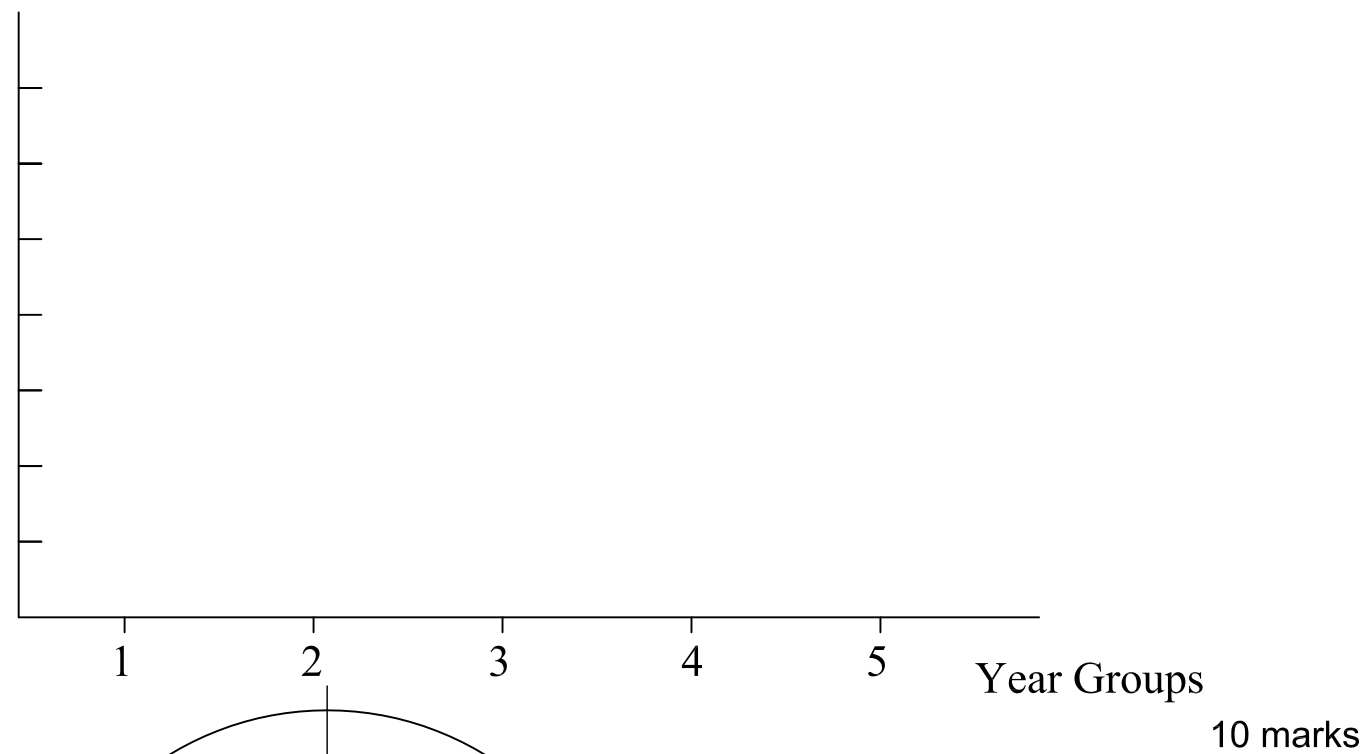

3. The figure below shows an irregular pentagon 'ABCDE'. By means of geometrical construction draw a square having the same area as the given pentagon. Measure and state the length of the side of the square to the nearest millimetre.

10 marks

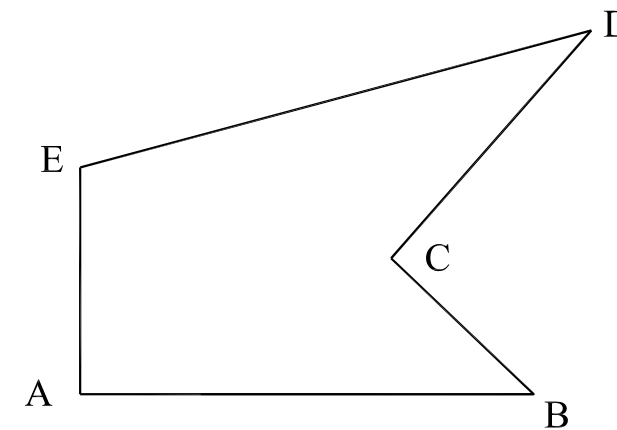

4. In the off-set crank mechanism shown, the slider - end B moves in guides along the line CD, below the axis O of the crank. Plot the locus of point P on rod AB for one complete revolution of crank OA.

15 marks

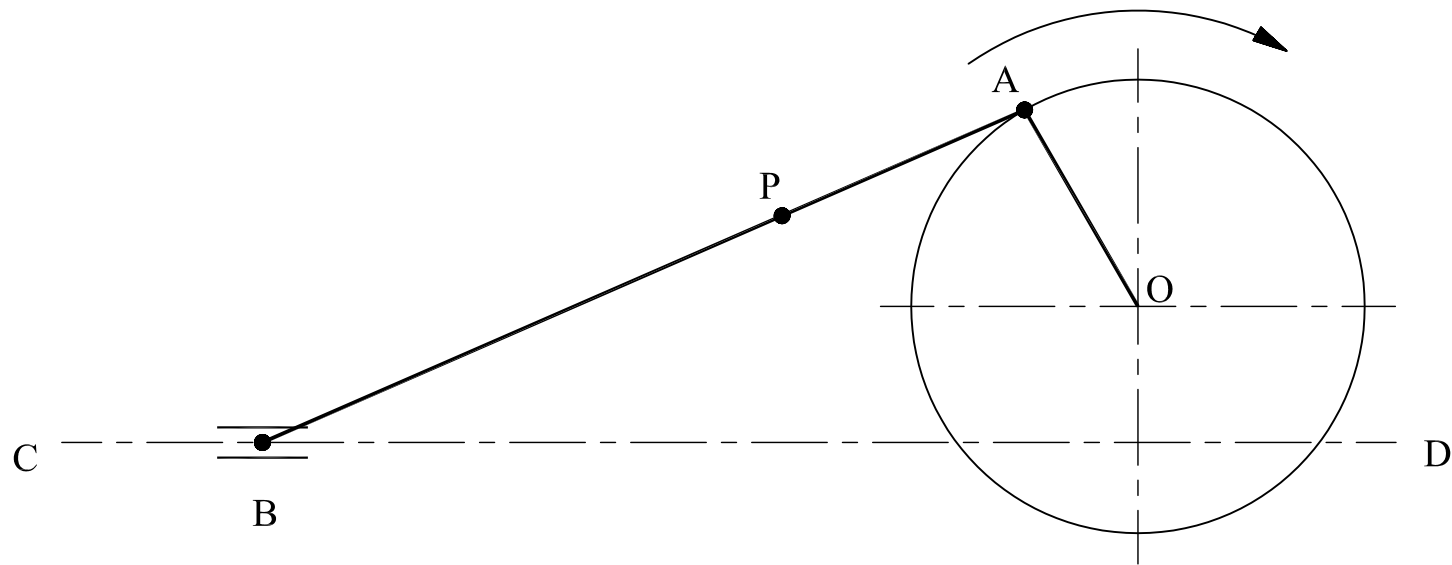

5. The figure below shows a complete surface development, a plan view and an incomplete front elevation of a sheet metal component.

Draw full size, the wrapped component when viewed in the direction of arrow 'X'.

Note: that the joint line 'AA' of the wrapped development is to be placed in front as indicated in the incomplete front elevation and plan.

20 marks

