

**JUNIOR LYCEUM and SECONDARY SCHOOL
ANNUAL EXAMINATIONS 2005**

Educational Assessment Unit – Education Division

FORM 3 (3rd year) TECHNICAL DESIGN Time :2 hours

Instructions

- Write your name and class on all sheets.
- Attempt **ALL** questions.
- All answers are to be drawn accurately, with instruments, unless otherwise stated.
- All construction lines **MUST** be left on each solution to show the method employed.
- Drawing aids may be used.
- **You are required to use one side of your paper for question number 1 only.**

Information

- All dimensions are in millimetres.
- Estimate any dimension not given.
- Marks will be awarded for accuracy, clarity and appropriateness of construction.

NAME : _____ **CLASS :** _____

Question	1	2	3	4	5
Max. mark	45	16	14	11	14
Mark					

1. The figure shows a pictorial view of a **CLAMP**.
 To the dimensions given and using **First Angle Projection**, draw the following views.

- | | | |
|-----|--|----------|
| (a) | a front elevation as seen from direction of arrow A | 12 marks |
| (b) | an end elevation as seen from direction of arrow B | 13 marks |
| (c) | a complete plan | 15 marks |
| (d) | the Symbol for the projection used and Scale | 5 marks |

Note: Insert all hidden details

(Total 45 marks)

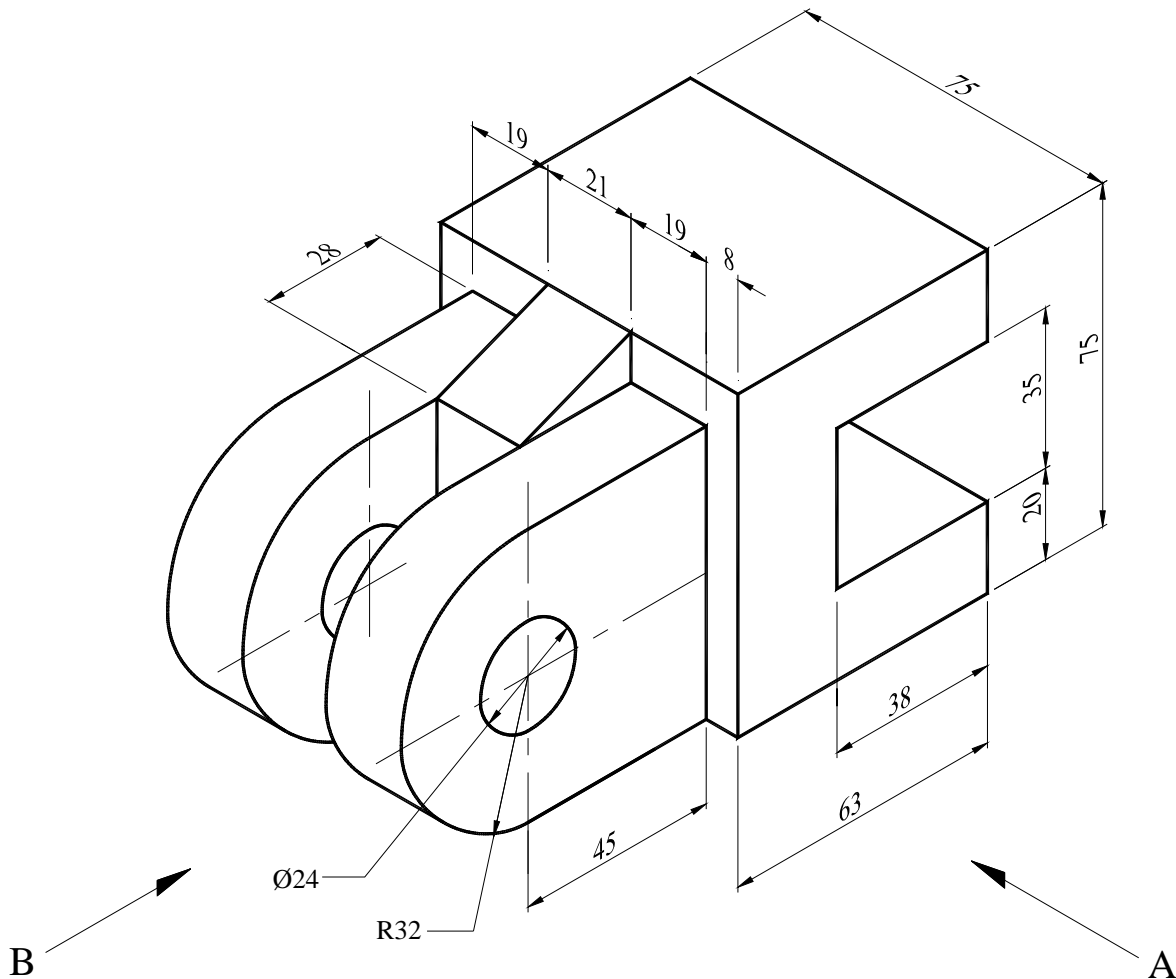

2. The figure shows the layout for a paper feed mechanism.
- Construct geometrically the outline to a scale of **1 : 2**.
 - Indicate the exact points of tangency by drawing short lines across the outline at these points.
 - All construction lines must be shown.

(16 marks)

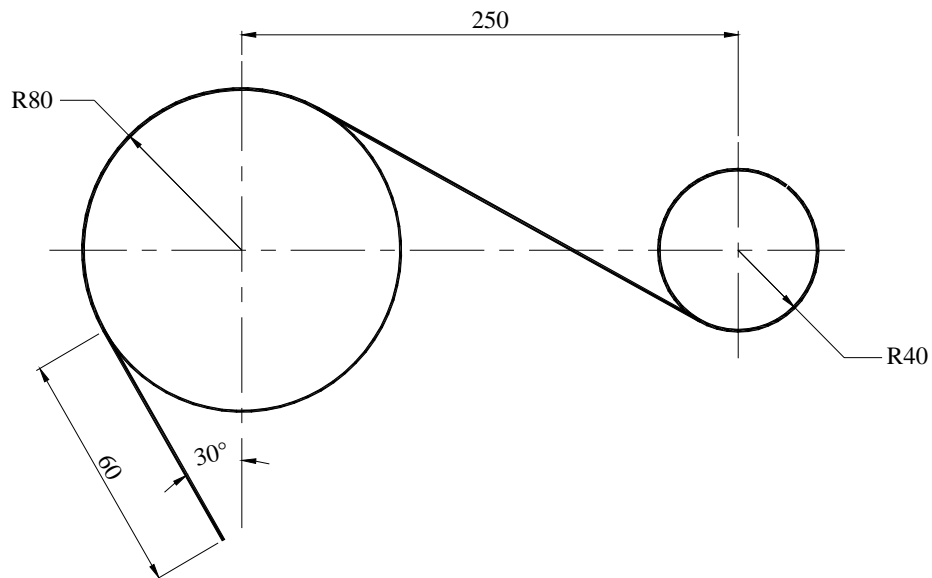

3. The figure shows the elevation of a company logo based on the letters **C** and **T** and an Isometric view showing the thickness of the letters. Draw, to the dimensions given a **CABINET OBLIQUE** of the Logo.

(14 marks)

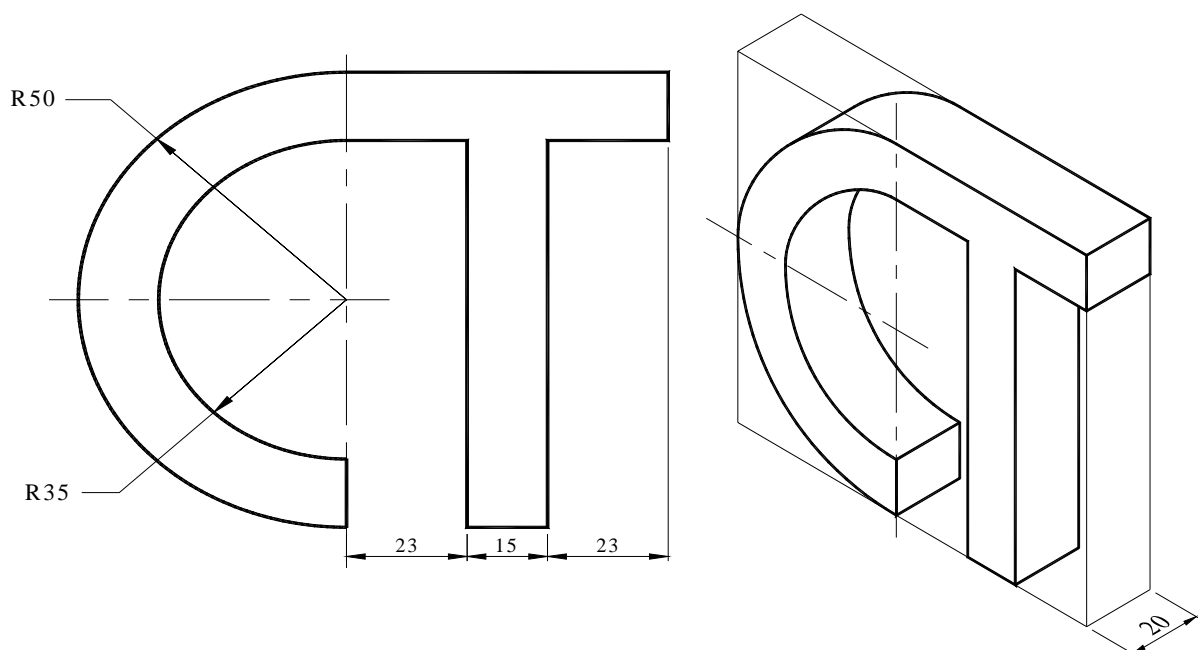

4. The figure shows the elevation and an incomplete plan of a truncated pyramid. A – A indicates the cutting plane.

To the dimensions given:

- (a) Copy the given elevation
- (b) Draw and complete the plan indicating the section
- (c) Construct or project the true shape of the section

(11 marks)

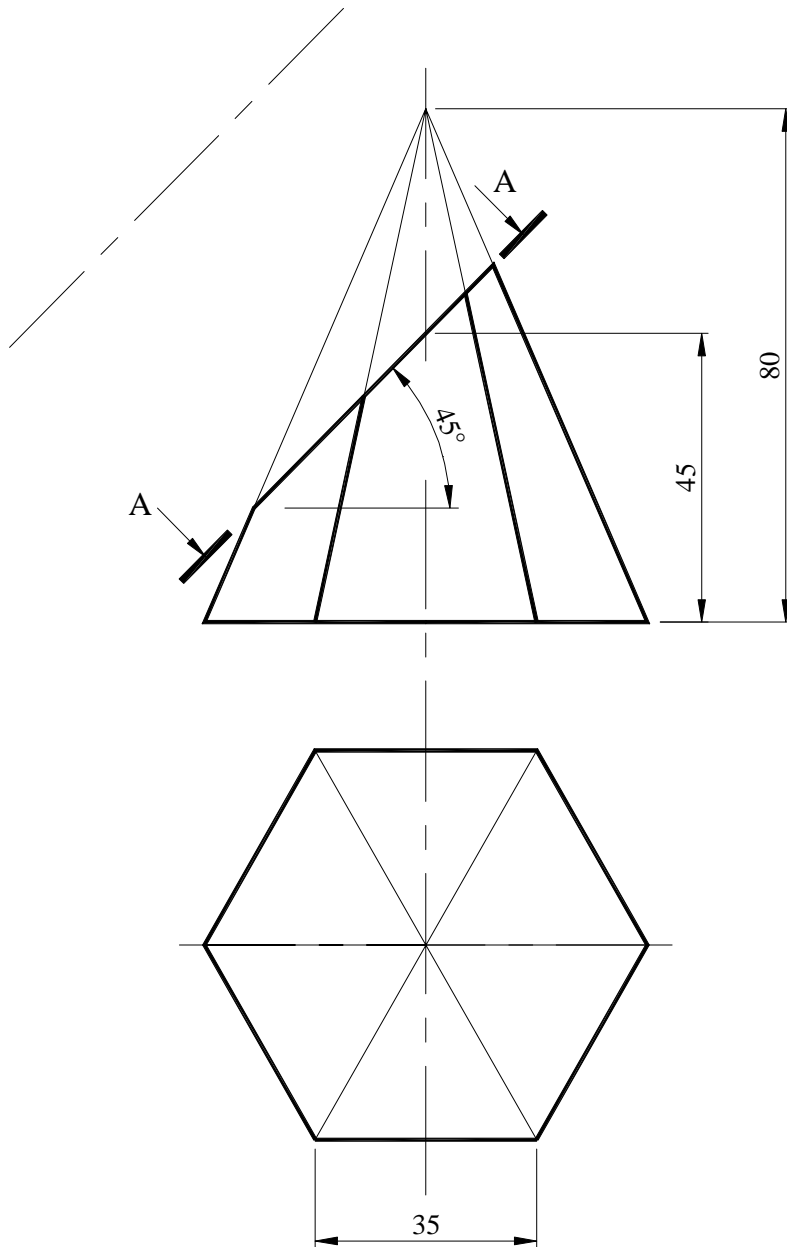

5. The figure shows an irregular quadrilateral ABCD and E.
- (a) Draw the quadrilateral shown to the dimensions given.
 - (b) Enlarge the given figure so that the sides are in the ratio of 3 : 2 .
 - (c) Calculate to the nearest millimeter the perimeter of the enlarged quadrilateral.

Side AB = 80mm Side AE = 55mm
Side BC = 34 Side ED = 44mm
Diagonal AC 95mm Side CD = 58mm

(14 marks)

